

Agilent 16900-Series Logic Analysis System

Installation Guide



Agilent Technologies

Notices

© Agilent Technologies, Inc. 2004-2005

No part of this manual may be reproduced in any form or by any means (including electronic storage and retrieval or translation into a foreign language) without prior agreement and written consent from Agilent Technologies, Inc. as governed by United States and international copyright laws.

Manual Part Number

16900-97004

Edition

Fourth edition, March 2005

Printed in Malaysia

Agilent Technologies, Inc.
1900 Garden of the Gods Road
Colorado Springs, CO 80907 USA

Trademark Acknowledgements

Windows and MS Windows are U.S. registered trademarks of Microsoft Corporation.

Windows NT is a U.S. registered trademark of Microsoft Corporation.

Warranty

The material contained in this document is provided “as is,” and is subject to being changed, without notice, in future editions. Further, to the maximum extent permitted by applicable law, Agilent disclaims all warranties, either express or implied, with regard to this manual and any information contained herein, including but not limited to the implied warranties of merchantability and fitness for a particular purpose. Agilent shall not be liable for errors or for incidental or consequential damages in connection with the furnishing, use, or performance of this document or of any information contained herein. Should Agilent and the user have a separate written agreement with warranty terms covering the material in this document that conflict with these terms, the warranty terms in the separate agreement shall control.

Technology Licenses

The hardware and/or software described in this document are furnished under a license and may be used or copied only in accordance with the terms of such license.

Restricted Rights Legend

If software is for use in the performance of a U.S. Government prime contract or subcontract, Software is delivered and licensed as “Commercial computer software” as defined in DFAR 252.227-7014 (June 1995), or as a “commercial item” as defined in FAR 2.101(a) or as “Restricted computer software” as defined in FAR 52.227-19 (June 1987) or any equivalent agency regulation or contract clause. Use, duplication or disclosure of Software is subject to Agilent Technologies’ standard commercial license terms, and non-DOD Departments and Agencies of the U.S. Government will receive no greater than Restricted Rights as

defined in FAR 52.227-19(c)(1-2) (June 1987). U.S. Government users will receive no greater than Limited Rights as defined in FAR 52.227-14 (June 1987) or DFAR 252.227-7015 (b)(2) (November 1995), as applicable in any technical data.

Safety Notices

CAUTION

A **CAUTION** notice denotes a hazard. It calls attention to an operating procedure, practice, or the like that, if not correctly performed or adhered to, could result in damage to the product or loss of important data. Do not proceed beyond a **CAUTION** notice until the indicated conditions are fully understood and met.

WARNING

A **WARNING** notice denotes a hazard. It calls attention to an operating procedure, practice, or the like that, if not correctly performed or adhered to, could result in personal injury or death. Do not proceed beyond a **WARNING** notice until the indicated conditions are fully understood and met.

Installation at a Glance

16900-Series Logic Analysis System Overview



The Agilent Technologies 16900-series logic analysis systems are modular systems with slots for logic analyzer and other types of measurement modules.

Table 1 Model comparisons

Agilent model number	16900A	16902A	16903A
Number of slots	6	6	3
Multiframe Pro	Yes	Yes	No
Display and resolution	Uses external display, supports up to four external displays at up to 1600 x 1200 (with PCI video card)	Built-in color touch screen display, 12.1 inch at 800 x 600, supports up to four external monitors at up to 1600 x 1200 (with PCI video card)	Built-in color touch screen display, 12.1 inch at 800 x 600, supports up to four external monitors at up to 1600 x 1200 (with PCI video card)
PCI expansion slots	2 full profile 1 low profile	2 full profile 1 low profile	1 full profile 1 low profile

All models have a familiar Windows-based user interface which takes the complexity out of making logic analyzer measurements. You can perform all operations directly from one window.

- Supplied Accessories:
 - PS2 mouse.
 - PS2 Mini keyboard.
 - Accessory pouch and power cord.
 - Ten-conductor flying lead cable for target control port.
- Optional Accessories:
 - Multiframe cable (E5861A).
 - 1 Gbit low-profile LAN card (Option 014 or E5860A).
 - Probes.

In This Guide

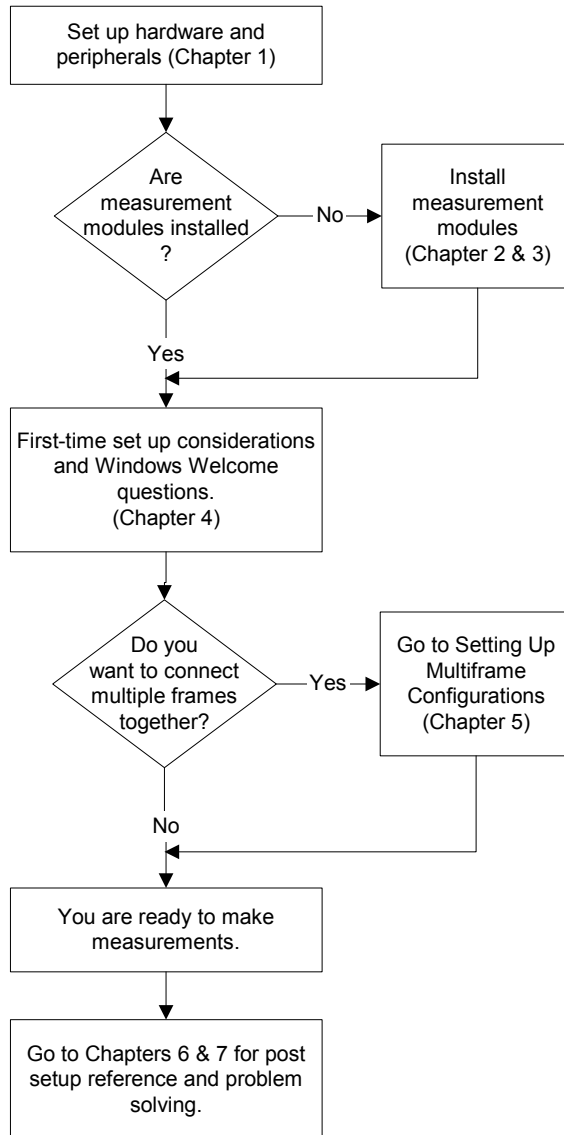

Contents

1 Setting Up Hardware

- To connect the mouse, keyboard, and monitor 12
- To connect to a LAN 14
- To connect a printer 15
- To connect an Infiniium oscilloscope time correlation fixture 16

2 Installing Logic Analyzer Cards and Probes

- Software Requirements 18
- To connect probes 18
- To replace thumb screws on measurement modules 19
- To install, remove, or replace measurement modules 20
- 16740/41/42A, 16750/51/52A/B Logic Analyzer (1-card module) 23
- 16740/41/42A, 16750/51/52A/B Logic Analyzer (2-card module) 24
- 16740/41/42A, 16750/51/52A/B Logic Analyzer (3-card module) 25
- 16740/41/42A, 16750/51/52A/B Logic Analyzer (4-card module) 26
- 16740/41/42A, 16750/51/52A/B Logic Analyzer (5-card module) 27
- 16753/54/55/56A, 16950A Logic Analyzer (1-card module) 28
- 16753/54/55/56A, 16950A Logic Analyzer (2-card module) 29
- 16753/54/55/56A, 16950A Logic Analyzer (3-card module) 30
- 16753/54/55/56A, 16950A Logic Analyzer (4-card module) 31
- 16753/54/55/56A, 16950A Logic Analyzer (5-card module) 32
- 16760A Logic Analyzer (1-card module) 33

16760A Logic Analyzer (2-card module)	34
16760A Logic Analyzer (3-card module)	35
16760A Logic Analyzer (4-card module)	36
16760A Logic Analyzer (5-card module)	37
16910A/11A Logic Analyzer (1-card module)	38
16910A/11A Logic Analyzer (2-card module)	39
16910A/11A Logic Analyzer (3-card module)	40
16910A/11A Logic Analyzer (4-card module)	41
16910A/11A Logic Analyzer (5-card module)	42

3 Installing Pattern Generator Cards

Software Requirements	44
16720A Pattern Generator (1-card module)	45
16720A Pattern Generator (2-card module)	46
16720A Pattern Generator (3-card module)	47
16720A Pattern Generator (4-card module)	48
16720A Pattern Generator (5-card module)	49

4 First-Time Set Up

First-Time Set Up Considerations	52
Determine Whether the Instrument will be Connected to the Network	52
Get Network Setup Information	52
Answering Windows Welcome Questions	54
If expected Windows Welcome questions do not appear	55
Additional First Time Setup Steps	56
Establishing an Administrator Account (recommended for standalone and networked instruments)	56
Protecting the Instrument's Operating System	56

5 Setting Up Multiframe Configurations

Setting Up Simple Multiframe Configurations	58
Simple 100 Base-T Multiframe Configuration	59
Simple 1000 Base-T Multiframe Configuration	60
Rules for Simple Multiframe Configurations	61
Creating Simple Multiframe Configurations	61
Remotely Controlling Simple Multiframe Systems	63
Simple 2-Frame w/Crossover Cable Configuration	64
Setting Up a Performance Multiframe Configuration	66
Rules for Performance Multiframe Configurations	67
Creating a Performance Multiframe Configuration	67
Remotely Controlling a Performance Multiframe System	70
Other Multiframe Configuration Notes	71
I/O in Multiframe Configurations	71
Licenses in Multiframe Configurations	71

6 Using and Updating the Logic Analysis System

To locate information on using the logic analyzer	74
Online Help	74
To locate specifications and characteristics	75
Electrical and Operating Environment Characteristics	75
More Specifications and Characteristics	76
To perform backups	77
To install software	77
Agilent Logic Analysis System Software	77
Optional Products	77
To install interface cards	78
1 Gbit LAN Card	82
To replace the CPU battery	83

To power off the system	84
Using the Windows Shutdown	84
Using a Short Press of the Power Button	84
Using a Long Press of the Power Button	85
Unplugging the Power Cord or Power Loss	85
To change network settings	85
To change Windows Firewall settings	87
To give other applications/ports access through the firewall	87
To restore the logic analysis system firewall defaults	89

7 Solving Problems

Running Self-Tests	94
If the logic analysis system powers itself down	95
16900A and 16902A logic analysis systems	95
All 16900-series logic analysis systems	96
If the Power LEDs do not come on	96
If you get a registry error and the system won't boot	96
If you can't write/read CDs	96
If there are multiframe connection problems	97
If there are network connection problems	99
Using the System Recovery Software	100
Contacting Agilent Service/Support	100

A Safety Notices

Warnings	101
To clean the instrument	102
Safety Symbols	102

Index

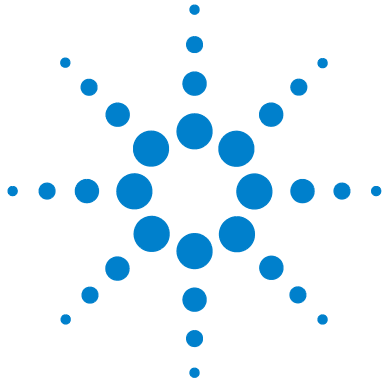

1 Setting Up Hardware

- To connect the mouse, keyboard, and monitor [12](#)
- To connect to a LAN [14](#)
- To connect a printer [15](#)
- To connect an Infiniium oscilloscope time correlation fixture [16](#)



To connect the mouse, keyboard, and monitor

The 16900A logic analysis system must have the system mouse and keyboard connected for the system to boot up properly. Once enabled on the LAN, the system can be operated remotely without a keyboard or mouse. Use of a monitor is optional for the 16902A and 16903A.

(The following rear panel figures are representative; yours may look different.)

- 1 Connect the provided PS/2 mouse and keyboard provided to the back of the 16900/02/03A.

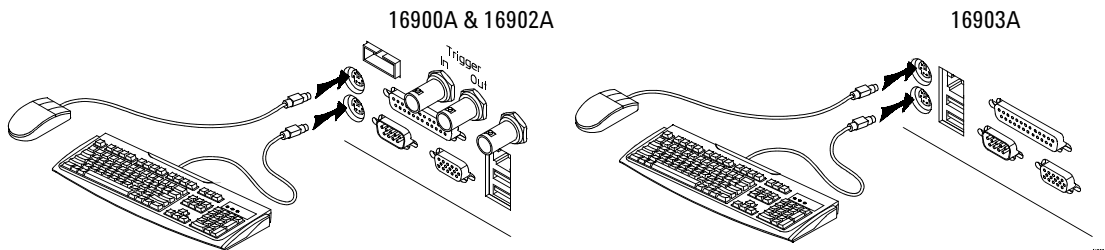

- 2 Connect a monitor to the back of the 16900A. A second monitor on your 169002/03A is optional.

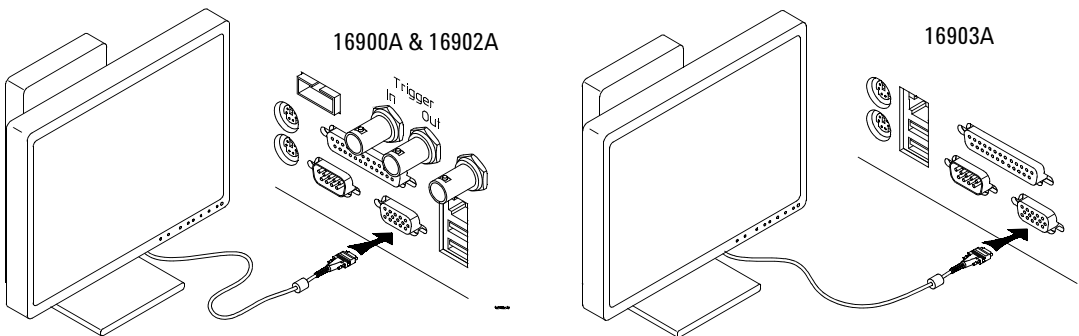

The touch off button switches the Windows desktop from one display device to another. A message will appear in one of the monitors telling you how to use this feature.

3 Connect the power cord supplied with your frame.

NOTE

The 16900A and 16902A have a special notched power cord in order to provide 1300W to the frame.

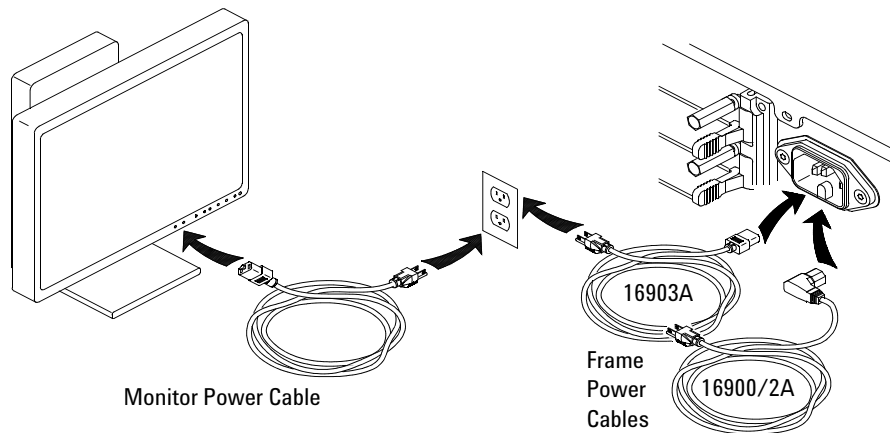

4 Allow a minimum of 15 cm (6 in.) spacing between instruments for proper cooling.

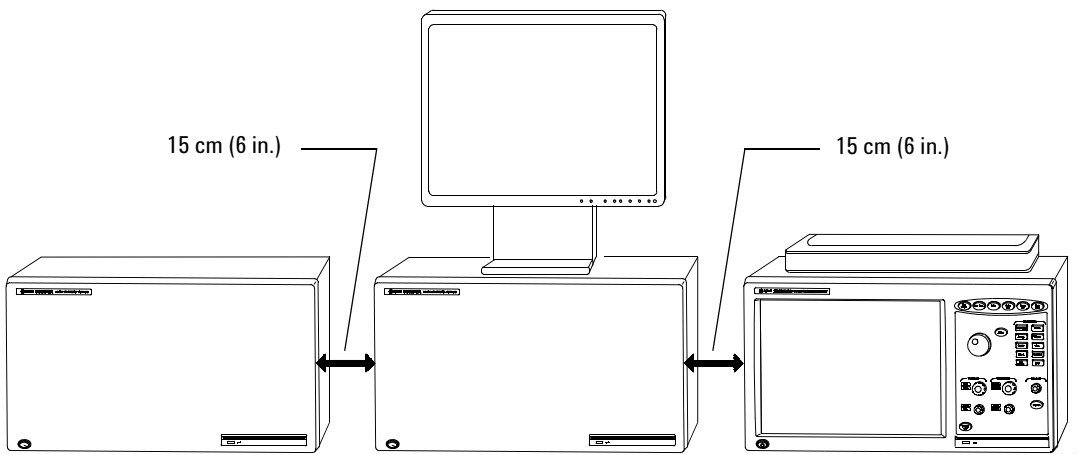

To connect to a LAN

Local area networks (LAN) are enabled outside of the logic analyzer application using the Windows network configuration wizard.

- 1 Connect the LAN cable(s) to the back of your logic analysis system.
 - Agilent recommends using a 1 Gbit LAN card when networking multiple frames. See [“To install interface cards”](#) on page 78 for information on installing a 1 Gbit LAN card in your system.
 - For information on network configurations when connecting multiple frames see [Chapter 5](#), “Setting Up Multiframe Configurations on [page 57](#).”

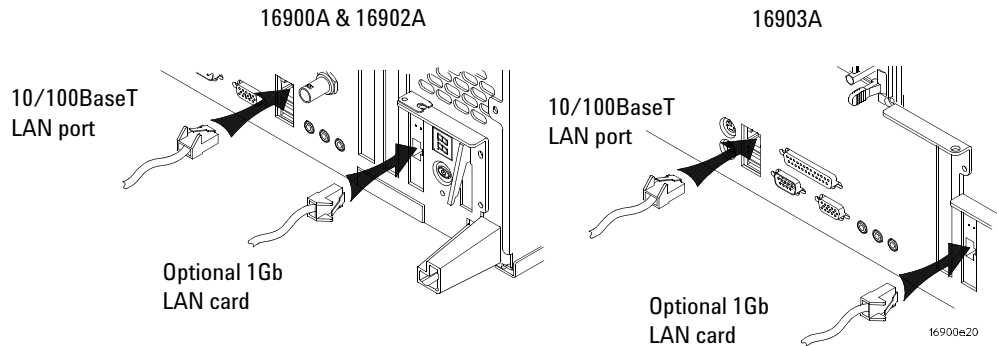

NOTE

Microsoft recommends the following three steps to ensure the instrument's PC is protected.

- a Use an internet firewall.
- b Get computer updates.
- c Use up-to-date antivirus software.

- 2 Refer to [“First-Time Set Up”](#) on page 51 to answer the Windows Welcome when you power up the logic analyzer.

To connect a printer

Local and network printers are added outside of the logic analyzer application using the Windows add printer wizard.

- 1** Connect the printer cable to the back of your logic analysis system. If using a network printer ensure the LAN cable is connected.
- 2** Click **Start>Settings>Printers>Add Printer**.
- 3** Follow the Windows add printer wizard instructions.

To connect an Infiniium oscilloscope time correlation fixture

The Agilent E5850A time correlation fixture allows you to make time-correlated measurements between an Agilent 16900-series logic analyzer and an Agilent Infiniium 548XX-series oscilloscope. Measurements between the logic analyzer and Infiniium oscilloscope are automatically de-skewed. The instruments communicate with one another through a LAN connection and Trigger In/Trigger Out. The time correlation fixture is used for calibration and deskew. The instruments connect to your device under test through separate probes, just as when they are used independently. The Infiniium time markers and two logic analysis system global markers are time-correlated and track each other.

To connect and use the time correlation fixture: in the logic analyzer application choose to **Setup>Advanced>Add External Scope...**

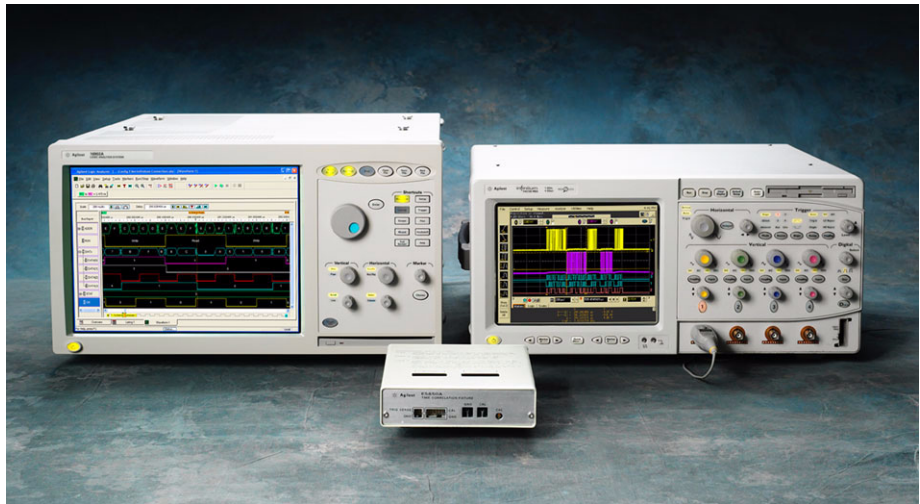

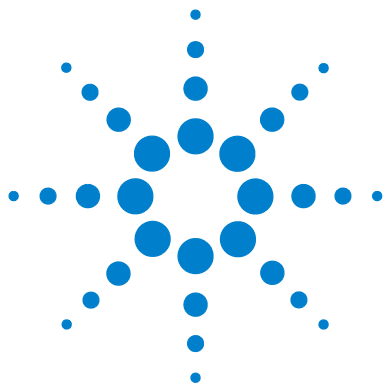

2 Installing Logic Analyzer Cards and Probes

Software Requirements	18
To connect probes	18
To replace thumb screws on measurement modules	19
To install, remove, or replace measurement modules	20
16740/41/42A, 16750/51/52A/B Logic Analyzer (1-card module)	23
16740/41/42A, 16750/51/52A/B Logic Analyzer (2-card module)	24
16740/41/42A, 16750/51/52A/B Logic Analyzer (3-card module)	25
16740/41/42A, 16750/51/52A/B Logic Analyzer (4-card module)	26
16740/41/42A, 16750/51/52A/B Logic Analyzer (5-card module)	27
16753/54/55/56A, 16950A Logic Analyzer (1-card module)	28
16753/54/55/56A, 16950A Logic Analyzer (2-card module)	29
16753/54/55/56A, 16950A Logic Analyzer (3-card module)	30
16753/54/55/56A, 16950A Logic Analyzer (4-card module)	31
16753/54/55/56A, 16950A Logic Analyzer (5-card module)	32
16760A Logic Analyzer (1-card module)	33
16760A Logic Analyzer (2-card module)	34
16760A Logic Analyzer (3-card module)	35
16760A Logic Analyzer (4-card module)	36
16760A Logic Analyzer (5-card module)	37
16910A/11A Logic Analyzer (1-card module)	38
16910A/11A Logic Analyzer (2-card module)	39
16910A/11A Logic Analyzer (3-card module)	40
16910A/11A Logic Analyzer (4-card module)	41
16910A/11A Logic Analyzer (5-card module)	42



Software Requirements

The following table gives you the Agilent Logic Analyzer software version required for logic analyzer measurement modules in the 16900A, 16902A, or 16903A frames. For information on updating your logic analysis system software go to “[To install software](#)” on page 77.

Table 2 Software Version Required

Model Number	Software Version
16740/41/42A, 16750/51/52A/B	02.00 or higher
16753/54/55/56A	02.00 or higher
16760A	3.20 or higher
16910A, 16911A	02.00 or higher
16950A	02.00 or higher

To connect probes

Probing is the key to effective and efficient use of logic analyzers. Agilent Technologies offers a wide variety of probing accessories that support general-purpose and application-specific measurement needs. We provide reliable, electrically and mechanically unobtrusive probes that make it easy to connect your Agilent logic analyzer to your system under test. For more information on Agilent probes:

- See the quick reference card that came with your logic analysis system for an overview of probing solutions.
- Go to www.agilent.com/find/logic_analyzer_probes for the most up-to-date information on probe compatibility with a given logic analyzer and purchasing information.
- Go to www.agilent.com and search for Probing Solutions for Logic Analyzers (publication [5968-4632E](#)) for a catalog of detailed probing information.

To connect and set up a probe, follow the instructions in the User’s Guide that came with the probe.

To replace thumb screws on measurement modules

If you ordered measurement modules with your logic analysis system, they will have the proper thumb screws and you can skip this procedure.

If you are using a measurement module from a 16700-series logic analysis system, you may need to replace the thumb screws. The rigid screws on these modules are not compatible with the new ejector levers.

- 1 Remove the retaining ring from the back of the panel then remove the thumb screw.
- 2 Insert the module sleeve into the front of the module panel and screw the nut onto it.
- 3 Screw the module screw into the sleeve.

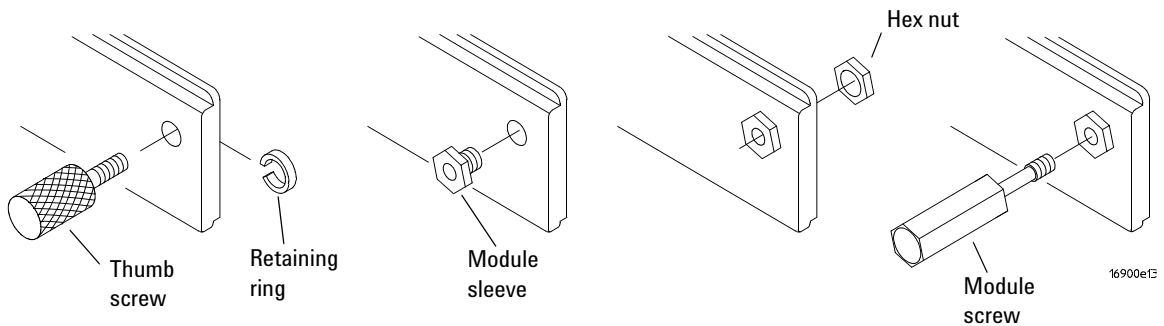

The 16900A/16902A logic analysis system comes with a set of 6 replacement thumb screws (16900-68713), and the 16903A logic analysis system comes with a set of 2 replacement thumb screws (16903-68713).

To install, remove, or replace measurement modules

If you ordered your measurement modules with the frame, they will already be installed and you can skip this procedure.

If you are using a measurement module from a 16700-series logic analysis system you will need to replace the thumb screws. Begin with the instructions on [page 19](#).

The following procedure guides you through installing, removing, or replacing measurement modules in the logic analysis system frame. Information on connecting specific multi-card measurement modules is in the next sections of this chapter. Measurement modules with different model numbers cannot be connected together in multi-card (Master/Expander) modules unless stated otherwise.

CAUTION

Electrostatic discharge can damage electronic components. Use grounded wrist straps and mats when performing any service to measurement modules.

- 1 Power down the system and disconnect the power cable before installing, removing or replacing measurement modules.

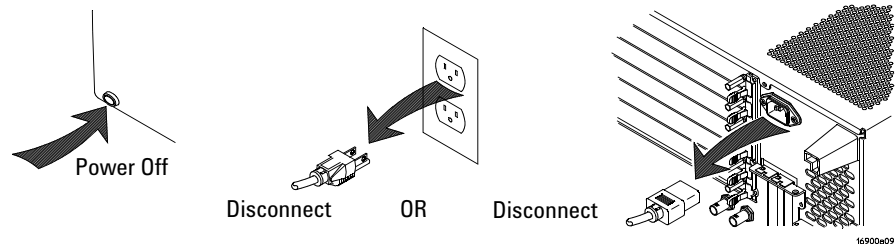

- 2 Remove filler panels as shown in the following figure.
 - a Loosen the thumb screws on the filler panels.
 - b Rotate the ejector levers from the locked position to the open position.
 - c Remove filler panels.

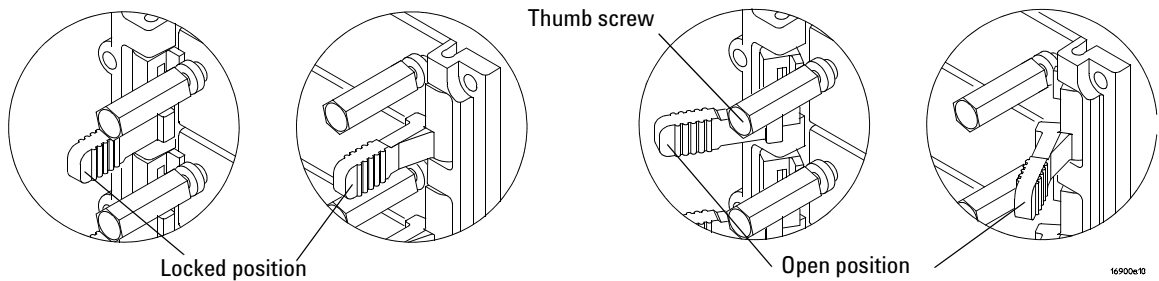

- 3 If you are using a measurement module from a 16700-series logic analysis system go to [“To replace thumb screws on measurement modules”](#) on page 19. If not, skip this step.
- 4 Ensure all ejectors are fully open and out of the way then slide the module(s) into the logic analysis system frame.

The following figure shows a 6-card frame. The insertion/removal order would be the same for a 3-card frame. A single-module configuration can be installed in any available slot.

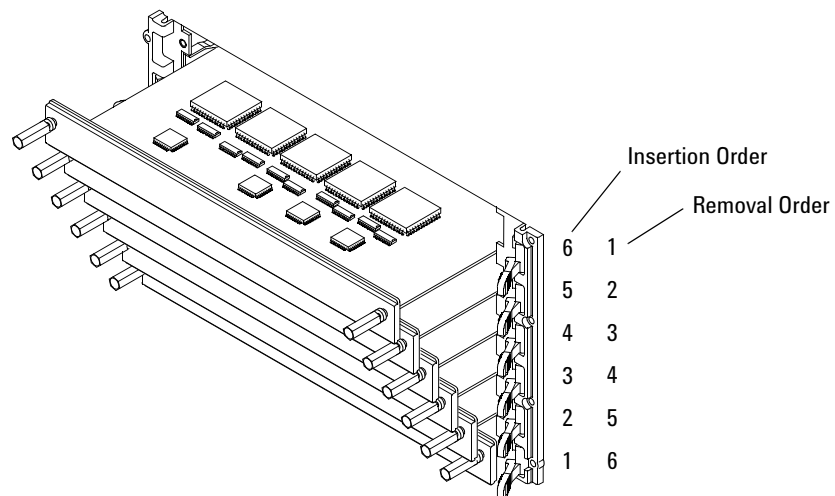

2 Installing Logic Analyzer Cards and Probes

- 5 Seat the modules then rotate the ejector tabs to the locked position. Repeat for all modules or filler panels.

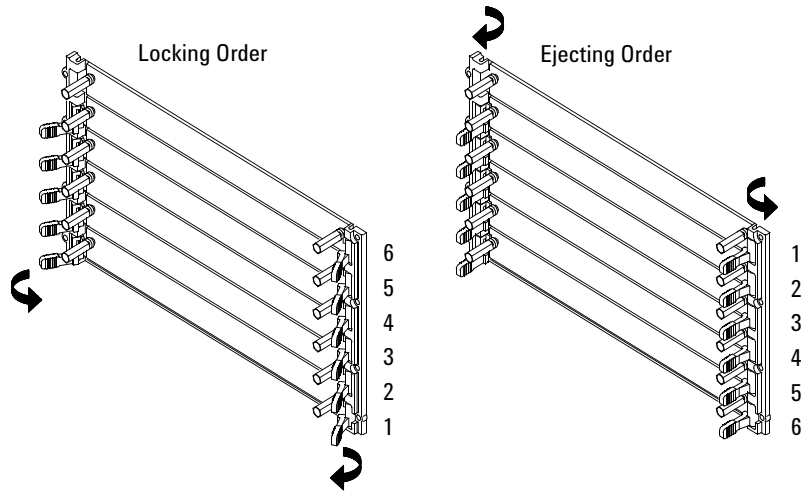

- 6 Tighten the thumb screws until finger tight in the same order used in step 5 above.
- 7 For correct air circulation, install filler panels in all unused card slots. Correct air circulation keeps the instrument from overheating. Keep any extra filler panels for future use.
- 8 Refer to "[First-Time Set Up](#)" on page 51 to answer the Windows Welcome questions when you power up the logic analysis system for the first time.

16740/41/42A, 16750/51/52A/B Logic Analyzer (1-card module)

Each card shipped stand-alone has the 2 x 10 cable connected in the single-card module configuration. A single-card module can be installed in any available slot.

NOTE

Turn off the mainframe power before removing, replacing, or installing modules. For instructions on installing modules into the logic analysis system frame, refer to [page 20](#).

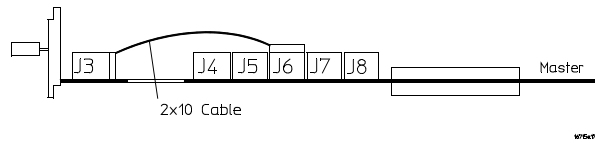

16740/41/42A, 16750/51/52A/B Logic Analyzer (2-card module)

Use two 2 x 10 cables and two 2 x 40 cables (in the accessory pouch) to connect the modules.

NOTE

Turn off the mainframe power before removing, replacing, or installing modules. For instructions on installing modules into the logic analysis system frame, refer to [page 20](#).

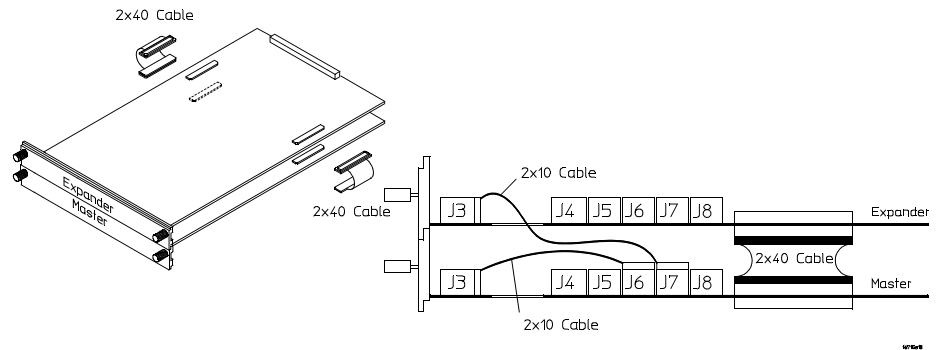

NOTE

Measurement modules with different model numbers cannot be connected together in multi-card modules. However, the 16750A may be connected to a 16750B; the 16751A may be connected to a 16751B; the 16752A may be connected to a 16752B.

16740/41/42A, 16750/51/52A/B Logic Analyzer (3-card module)

Use three 2 x 10 cables and four 2 x 40 cables (in the accessory pouch) to connect the modules.

NOTE

Turn off the mainframe power before removing, replacing, or installing modules. For instructions on installing modules into the logic analysis system frame, refer to [page 20](#).

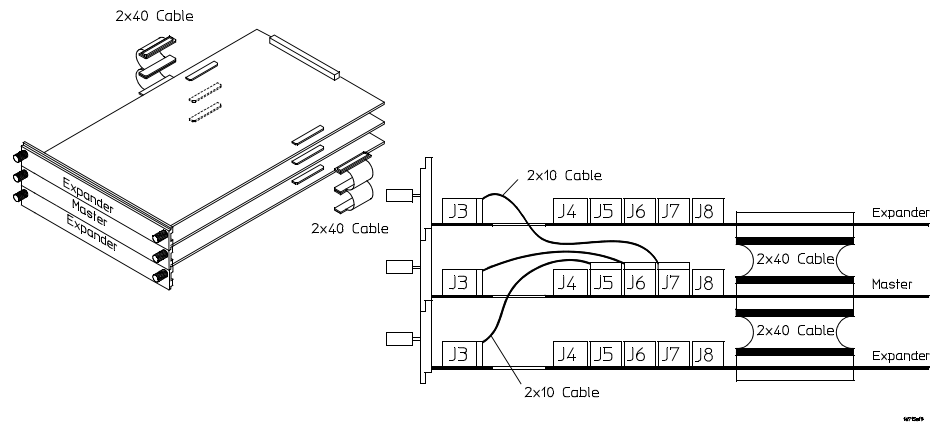

NOTE

Measurement modules with different model numbers cannot be connected together in multi-card modules. However, the 16750A may be connected to a 16750B; the 16751A may be connected to a 16751B; the 16752A may be connected to a 16752B.

16740/41/42A, 16750/51/52A/B Logic Analyzer (4-card module)

Use four 2 x 10 cables and six 2 x 40 cables (in the accessory pouch) to connect the modules.

NOTE

Turn off the mainframe power before removing, replacing, or installing modules. For instructions on installing modules into the logic analysis system frame, refer to [page 20](#).

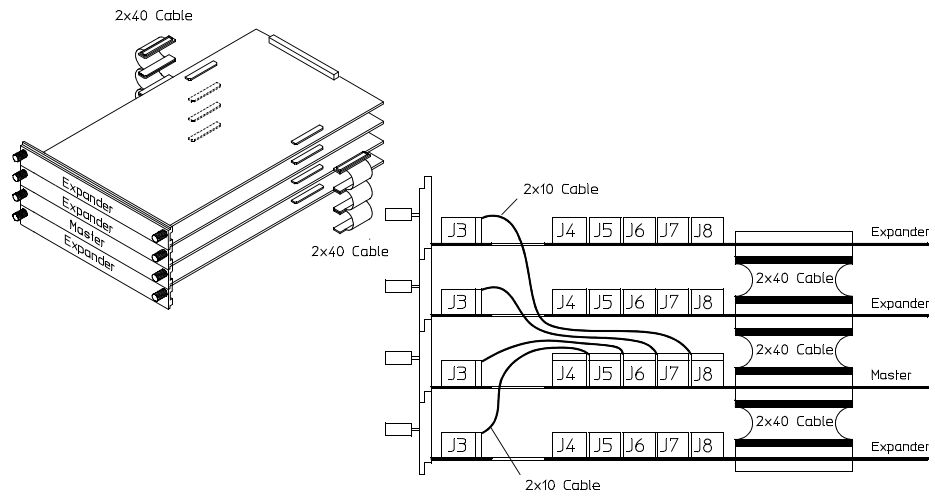

NOTE

Measurement modules with different model numbers cannot be connected together in multi-card modules. However, the 16750A may be connected to a 16750B; the 16751A may be connected to a 16751B; the 16752A may be connected to a 16752B.

16740/41/42A, 16750/51/52A/B Logic Analyzer (5-card module)

Use five 2 x 10 cables and eight 2 x 40 cables (in the accessory pouch) to connect the modules

NOTE

Turn off the mainframe power before removing, replacing, or installing modules. For instructions on installing modules into the logic analysis system frame, refer to [page 20](#).

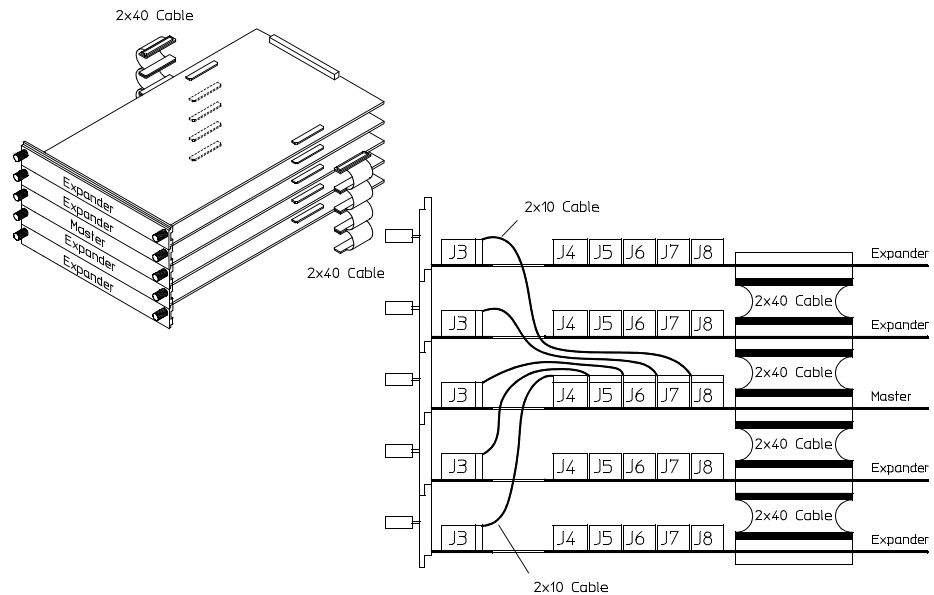

NOTE

Measurement modules with different model numbers cannot be connected together in multi-card modules. However, the 16750A may be connected to a 16750B; the 16751A may be connected to a 16751B; the 16752A may be connected to a 16752B.

2 Installing Logic Analyzer Cards and Probes

16753/54/55/56A, 16950A Logic Analyzer (1-card module)

Each card shipped stand-alone has the 2 x 15 cable connected in the single-card module configuration. The 2 x 50 cables in the accessory pouch are not used. A single-card module can be installed in any available slot.

NOTE

Turn off the mainframe power before removing, replacing, or installing modules. For instructions on installing modules into the logic analysis system frame, refer to [page 20](#).

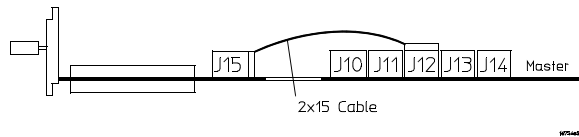

16753/54/55/56A, 16950A Logic Analyzer (2-card module)

Use two 2 x 15 cables and two 2 x 50 cables (in the accessory pouch) to connect the modules.

NOTE

Turn off the mainframe power before removing, replacing, or installing modules. For instructions on installing modules into the logic analysis system frame, refer to [page 20](#).

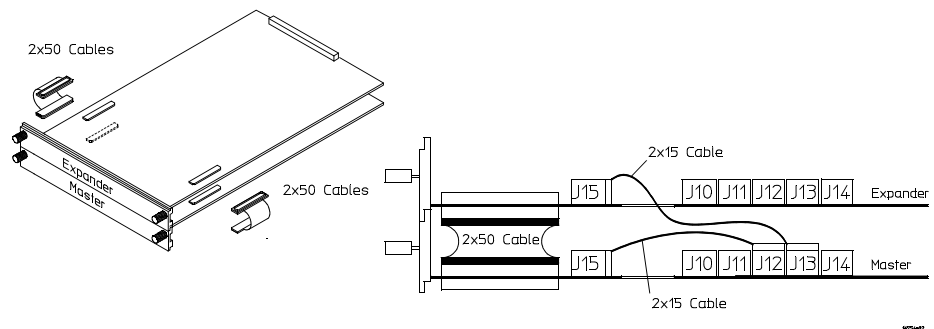

NOTE

You can combine any combination of 16753A, 16754A, 16755A, 16756A, and 16950As in a 2-card set. The combined set will default to the lowest memory depth in the set.

16753/54/55/56A, 16950A Logic Analyzer (3-card module)

Use three 2 x 15 cables and four 2 x 50 cables (in the accessory pouch) to connect the modules.

NOTE

Turn off the mainframe power before removing, replacing, or installing modules. For instructions on installing modules into the logic analysis system frame, refer to [page 20](#).

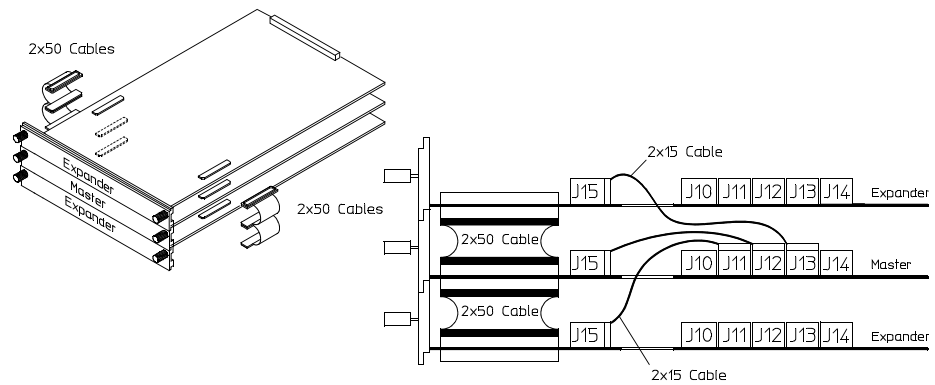

NOTE

You can combine any combination of 16753A, 16754A, 16755A, 16756A, and 16950As in a 3-card set. The combined set will default to the lowest memory depth in the set.

16753/54/55/56A, 16950A Logic Analyzer (4-card module)

Use four 2 x 15 cables and six 2 x 50 cables (in the accessory pouch) to connect the modules.

NOTE

Turn off the mainframe power before removing, replacing, or installing modules. For instructions on installing modules into the logic analysis system frame, refer to [page 20](#).

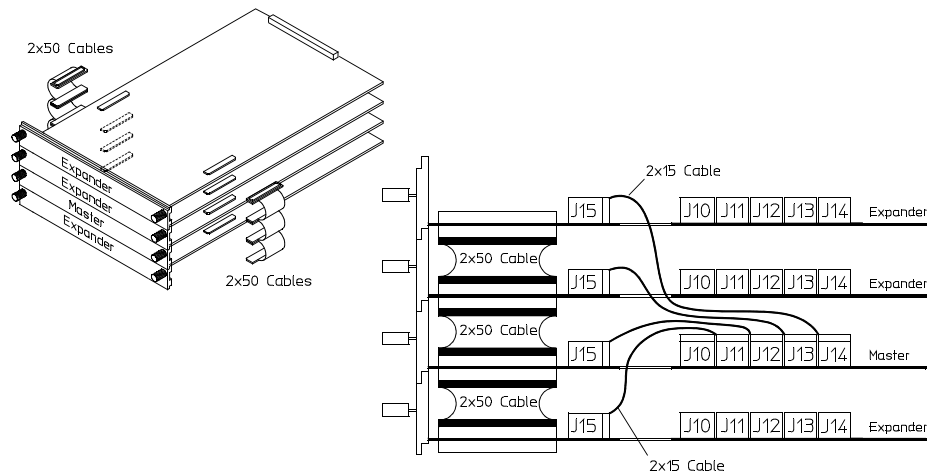

NOTE

You can combine any combination of 16753A, 16754A, 16755A, 16756A, and 16950As in a 4-card set. The combined set will default to the lowest memory depth in the set.

16753/54/55/56A, 16950A Logic Analyzer (5-card module)

Use five 2 x 15 cables and eight 2 x 50 cables (in the accessory pouch) to connect the modules.

NOTE

Turn off the mainframe power before removing, replacing, or installing modules. For instructions on installing modules into the logic analysis system frame, refer to [page 20](#).

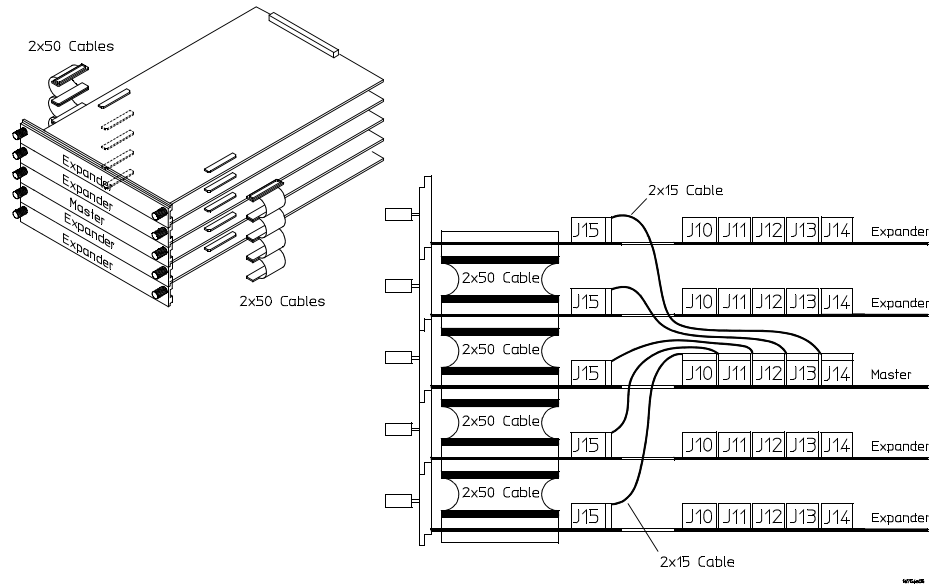

NOTE

You can combine any combination of 16753A, 16754A, 16755A, 16756A, and 16950As in a 5-card set. The combined set will default to the lowest memory depth in the set.

16760A Logic Analyzer (1-card module)

A single 16760A logic analyzer module will have the 2 x 10 cable connected in the single-card configuration.

NOTE

Turn off the mainframe power before removing, replacing, or installing modules following the procedures on page 42.

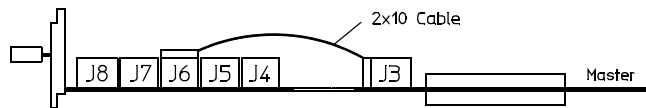

16760A Logic Analyzer (2-card module)

Use two 2 x 10 cables and two 2 x 40 cables (in the accessory pouch) to connect the modules.

NOTE

Turn off the mainframe power before removing, replacing, or installing modules following the procedures on page 42.

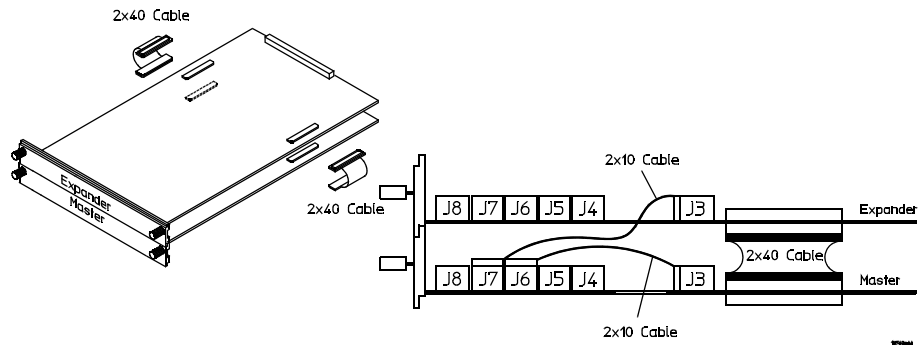

16760A Logic Analyzer (3-card module)

Use three 2 x 10 cables and four 2 x 40 cables (in the accessory pouch) to connect the modules.

NOTE

Turn off the mainframe power before removing, replacing, or installing modules following the procedures on page 42.

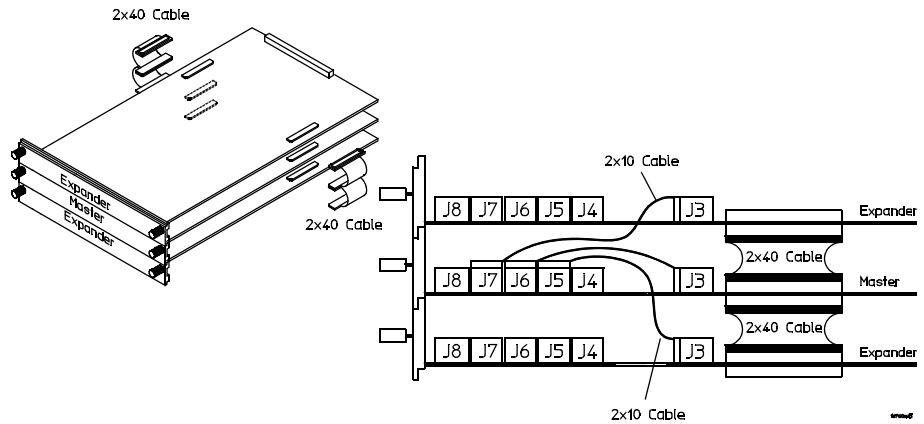

16760A Logic Analyzer (4-card module)

Use four 2 x 10 cables and six 2 x 40 cables (in the accessory pouch) to connect the modules.

NOTE

Turn off the mainframe power before removing, replacing, or installing modules following the procedures on page 42.

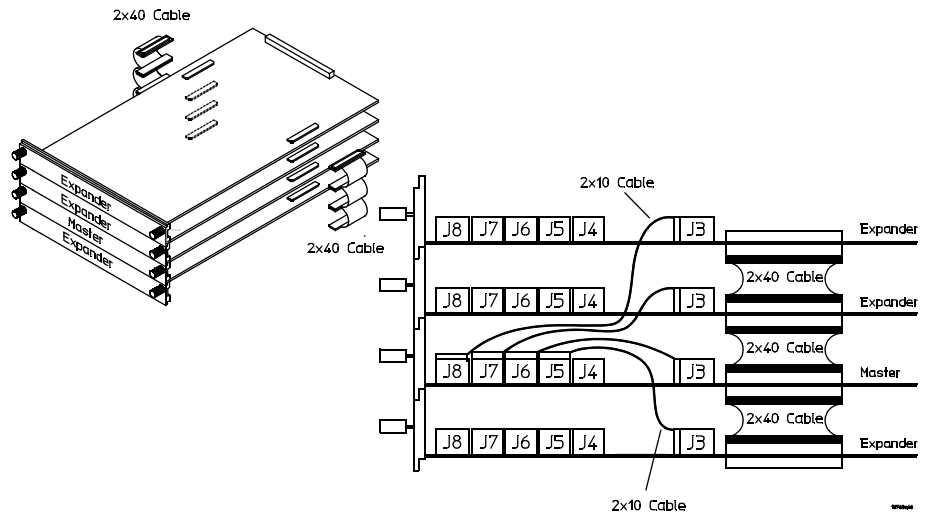

16760A Logic Analyzer (5-card module)

Use five 2 x 10 cables and eight 2 x 40 cables (in the accessory pouch) to connect the modules.

NOTE

Turn off the mainframe power before removing, replacing, or installing modules following the procedures on page 42.

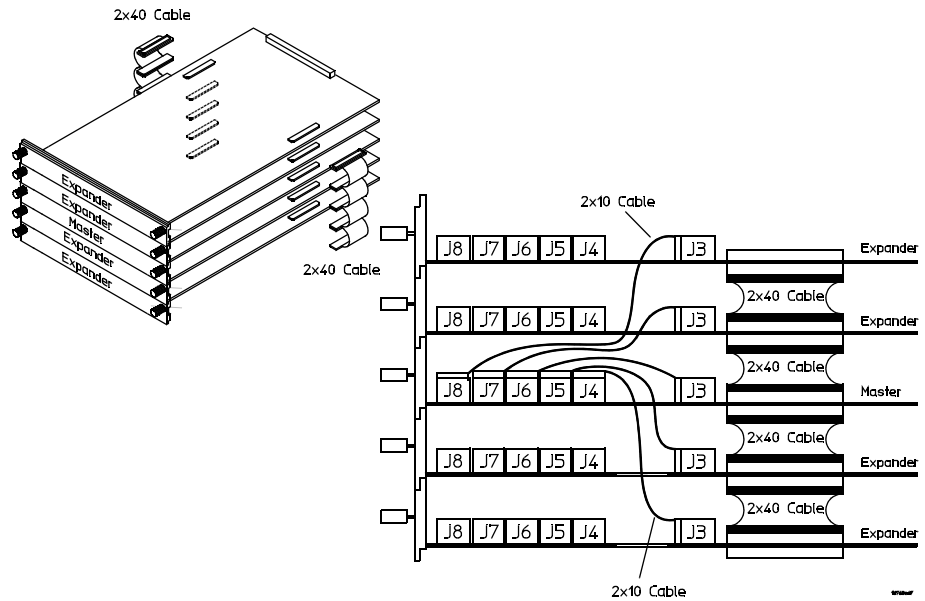

16910A/11A Logic Analyzer (1-card module)

Each card shipped stand-alone has the 2 x 15 cable connected in the single-card module configuration. The 2 x 50 cables in the accessory pouch are not used. A single-card module can be installed in any available slot.

NOTE

Turn off the mainframe power before removing, replacing, or installing modules. For instructions on installing modules into the logic analysis system frame, refer to [page 20](#).

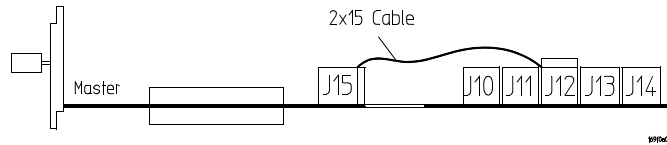

16910A/11A Logic Analyzer (2-card module)

Use two 2 x 15 cables and two 2 x 50 cables (in the accessory pouch) to connect the modules.

NOTE

Turn off the mainframe power before removing, replacing, or installing modules. For instructions on installing modules into the logic analysis system frame, refer to [page 20](#).

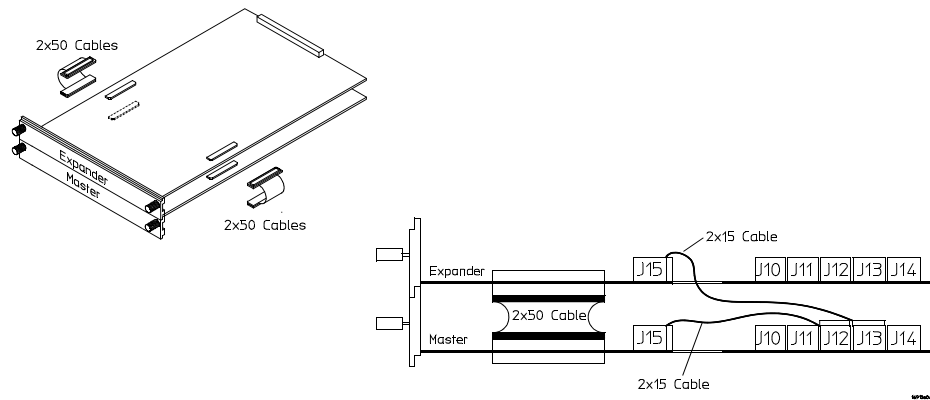

NOTE

You can combine the same model numbers only (16910A in a 2-card set or 16911A in a 2-card set). The combined set will default to the lowest state speed and memory depth in the set.

16910A/11A Logic Analyzer (3-card module)

Use three 2 x 15 cables and four 2 x 50 cables (in the accessory pouch) to connect the modules.

NOTE

Turn off the mainframe power before removing, replacing, or installing modules. For instructions on installing modules into the logic analysis system frame, refer to [page 20](#).

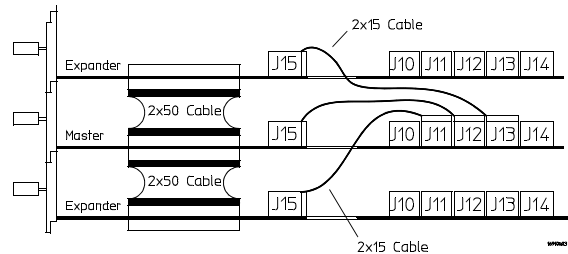
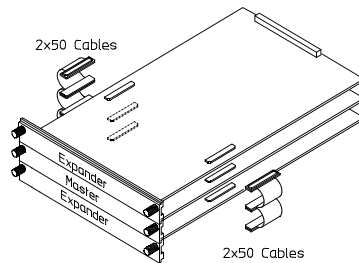

NOTE

You can combine the same model numbers only (16910A in a 3-card set or 16911A in a 3-card set). The combined set will default to the lowest state speed and memory depth in the set.

16910A/11A Logic Analyzer (4-card module)

Use four 2 x 15 cables and six 2 x 50 cables (in the accessory pouch) to connect the modules.

NOTE

Turn off the mainframe power before removing, replacing, or installing modules. For instructions on installing modules into the logic analysis system frame, refer to [page 20](#).

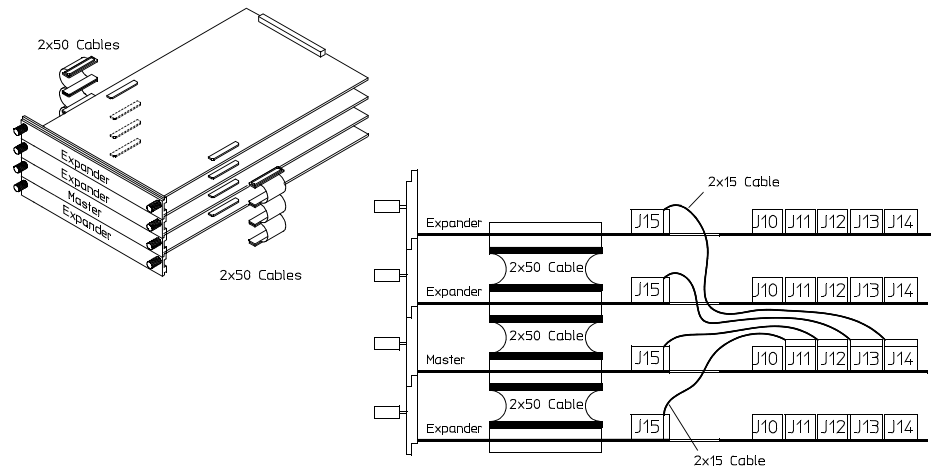

NOTE

You can combine the same model numbers only (16910A in a 4-card set or 16911A in a 4-card set). The combined set will default to the lowest state speed and memory depth in the set.

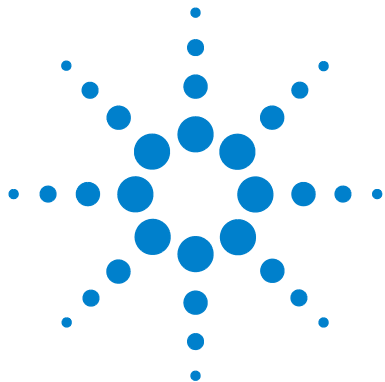

3 Installing Pattern Generator Cards

Software Requirements	44
16720A Pattern Generator (1-card module)	45
16720A Pattern Generator (2-card module)	46
16720A Pattern Generator (3-card module)	47
16720A Pattern Generator (4-card module)	48
16720A Pattern Generator (5-card module)	49



Software Requirements

The following table gives you the Agilent Logic Analyzer software version required for pattern generator measurement modules in the 16900A, 16902A, or 16903A frames. For information on updating your logic analysis system software go to [“To install software”](#) on page 77.

Table 3 Software Version Required

Model Number	Software Version
16720A	03.00 or higher

16720A Pattern Generator (1-card module)

Each card shipped stand-alone has the 2 x 10 cable connected in the single-card module configuration. A single-card module can be installed in any available slot.

NOTE

Turn off the mainframe power before removing, replacing, or installing modules. For instructions on installing modules into the logic analysis system frame, refer to [page 20](#).

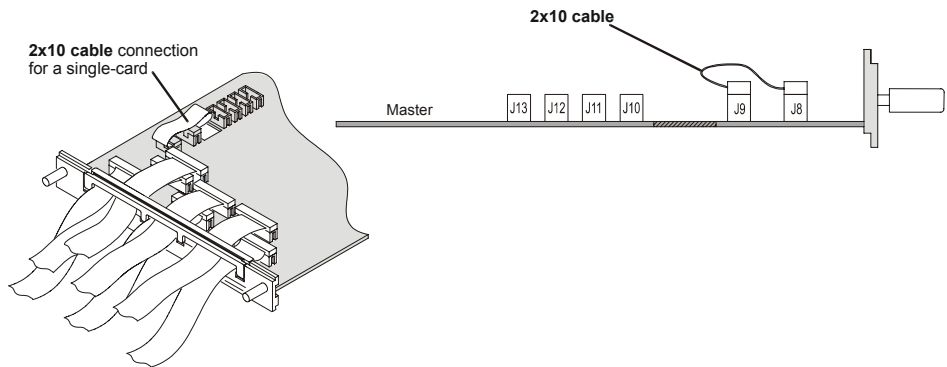

3 Installing Pattern Generator Cards

16720A Pattern Generator (2-card module)

Use two 2 x 10 cables to connect the modules.

NOTE

Turn off the mainframe power before removing, replacing, or installing modules. For instructions on installing modules into the logic analysis system frame, refer to [page 20](#).

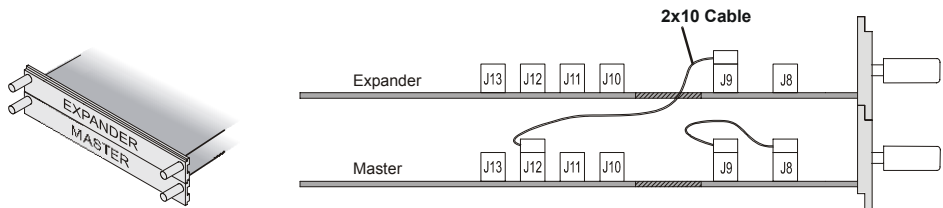

16720A Pattern Generator (3-card module)

Use three 2 x 10 cables to connect the modules.

NOTE

Turn off the mainframe power before removing, replacing, or installing modules. For instructions on installing modules into the logic analysis system frame, refer to [page 20](#).

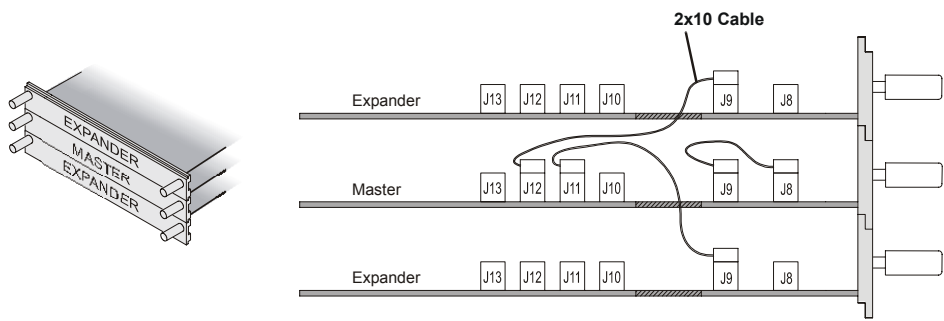

16720A Pattern Generator (4-card module)

NOTE

Turn off the mainframe power before removing, replacing, or installing modules. For instructions on installing modules into the logic analysis system frame, refer to [page 20](#).

- 1 Carefully slide the 4 cards half way into the mainframe slots.
- 2 Use four 2 x 10 cables to connect the modules. Cable the bottom Expander Card to the Master Card first. Then cable the upper two Expander Cards to the Master Card.
- 3 Gently slide the cabled assembly fully into the frame and tighten the thumb screws.

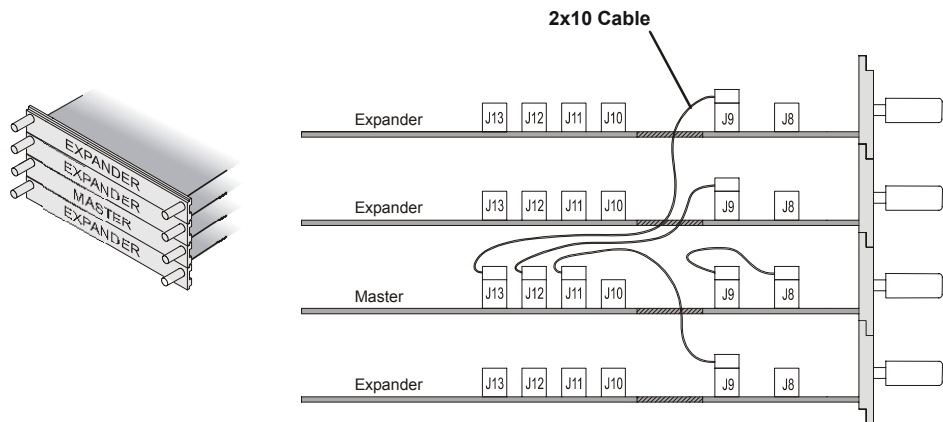

16720A Pattern Generator (5-card module)

NOTE

Turn off the mainframe power before removing, replacing, or installing modules. For instructions on installing modules into the logic analysis system frame, refer to [page 20](#).

- 1 Carefully slide the 4 cards half way into the mainframe slots.
- 2 Use six 2 x 10 cables to connect the modules. Cable the bottom two Expander Cards to the Master Card first. Then cable the upper two Expanders to the Master Card.
- 3 Gently slide the cabled assembly fully into the frame and tighten the thumb screws.

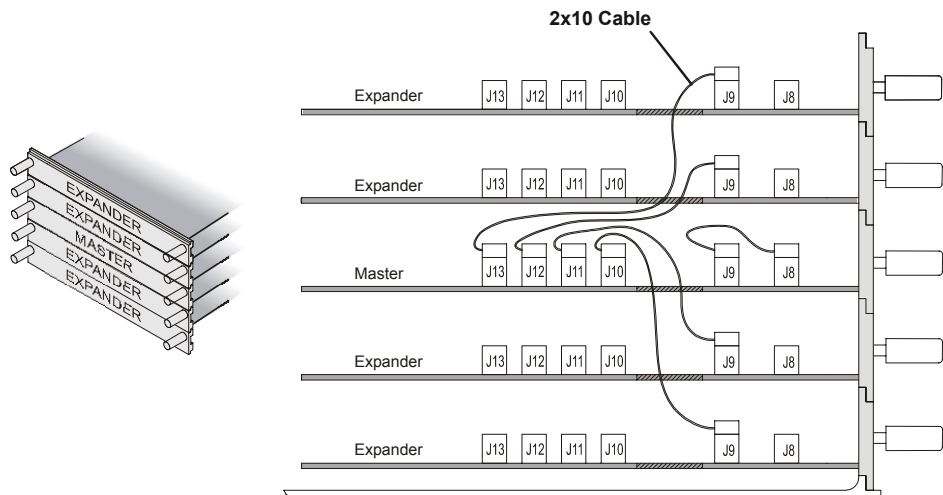

3 Installing Pattern Generator Cards

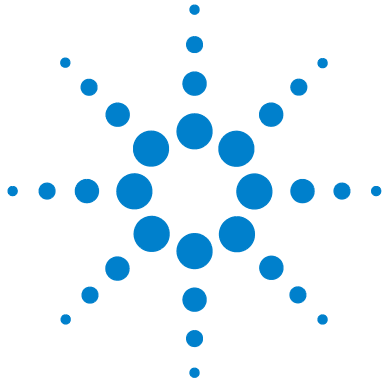

4 First-Time Set Up

First-Time Set Up Considerations	52
Answering Windows Welcome Questions	54
Additional First Time Setup Steps	56



First-Time Set Up Considerations

The first time you turn on the logic analysis system, the Windows Welcome session starts. Your logic analyzer configuration and the answers to the Windows Welcome questions are affected by how you choose to use the logic analyzer.

NOTE

Use the Enter and arrow keys on the attached keyboard. The logic analyzer front-panel keys do not work until Windows is running.

Determine Whether the Instrument will be Connected to the Network

NOTE

If you plan to use COM automation to programmatically control a logic analysis system from a remote computer, be aware that the remote computer and the logic analysis system must both have the same kind of network membership; that is, they must both be members of a "Workgroup", or they must both be members of a "Domain". This is due to the security requirements of Distributed COM.

Standalone

You are going to use the logic analysis system as a standalone instrument (no LAN connection). Printing requires a printer attached to the logic analyzer, sharing files is done via CD, USB flash drive, etc.

Connected to a Network

If you require the ability to print, share files, remotely control the logic analyzer, etc. over the network, you need to either join a workgroup or domain.

Get Network Setup Information

For networking, find out whether the network that your instrument will be connected to uses the Microsoft Workgroup model or Microsoft Domain model. In order for your instrument to perform tasks over the network (print, transfer files, etc.) your instrument must be configured appropriately for the networking model in use at your site.

Information you may require to complete your network configuration may include, but is not limited to,

- The Workgroup or Domain name.
- Methodology for assigning IP addresses at your site (for example, DHCP).
- Domain Name Service (DNS). This can also be obtained automatically.
- Other network information that may be readily available from your network administrator.

Answering Windows Welcome Questions

Once you have determined how you want to use your logic analyzer and your network configuration, power up your logic analyzer and answer the Windows Welcome questions.

Table 4 Answering Windows Welcome Questions

	Standalone (No LAN)	Workgroup	Domain
Help protect your PC	N/A	Choose "Help protect my PC by turning on Automatic Updates now".	Choose "Help protect my PC by turning on Automatic Updates now".
What's your computer's name? (After answering, wait several minutes for next question to appear)	If your organization has a standard naming scheme, use that scheme. Otherwise, choose a descriptive name that follows the suggestions on the screen (less than 15 characters, etc.)		
What's your administrator password?	Agilent recommends entering an administrator password for administrator accounts. See page 56 for actions that require administrator accounts.		
Is this computer in a domain?	No (Is given WORKGROUP membership)	No (Is given WORKGROUP membership)	Yes Enter the domain name the logic analysis system will log onto.
Enter your domain settings.	N/A	N/A	Enter the name/password of a user who can add the logic analysis system to the domain.
Checking your Internet connectivity	Press 'Skip'	Wait for this to finish.	Wait for this to finish.
How will this computer connect to the Internet?	N/A	N/A	Choose the appropriate answer.
Setting up a high-speed connection?	N/A	N/A	Enter either the fixed IP/DNS assigned by your network administrator or select "Obtain Automatically".

Table 4 Answering Windows Welcome Questions (continued)

	Standalone (No LAN)	Workgroup	Domain
(If LAN connected) Will this computer connect to the Internet directly, or through a network?	N/A	Choose "Yes, through a network" (Agilent does not support connecting to the internet through a modem directly connected to the logic analyzer.)	N/A
(If LAN is not connected) Windows unable to determine LAN connectivity.	N/A	You are told to set up LAN later.	N/A
Ready to register with Microsoft	Windows XP is already enabled to run on the logic analyzer. This registration is to allow Microsoft to contact you.		
Who will use this computer?	For All: Entering names here lets multiple users use the logic analyzer with administrator permissions. By default their passwords will be blank.		

If expected Windows Welcome questions do not appear

During first-time power-up, depending on the configuration of your network, some of the Windows Welcome questions that should appear, like "Is this computer in a domain?", may not appear.

If this occurs, you need to change the logic analysis system's network setup (after the first-time power up) using the normal Windows XP methods (see "[To change network settings](#)" on page 85).

Additional First Time Setup Steps

Establishing an Administrator Account (recommended for standalone and networked instruments)

Agilent recommends that you set up an Administrator account for your logic analysis system. You have to be logged in to the Administrator account to do the following:

- Install most software (applies whether the instrument is networked or standalone).
- Change the workgroup.
- Perform "Windows Updates".
- Change firewall settings.

Protecting the Instrument's Operating System

Microsoft recommends the following three steps to ensure the instrument's PC is protected.

- 1 Use an internet firewall.
- 2 Get operating system updates.
- 3 Use up-to-date antivirus software.

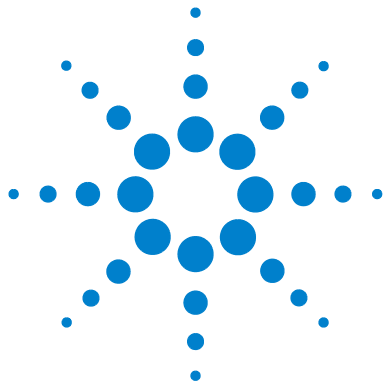

5 Setting Up Multiframe Configurations

Setting Up Simple Multiframe Configurations 58

Setting Up a Performance Multiframe Configuration 66

Other Multiframe Configuration Notes 71

If you need to make time-correlated measurements with more logic analysis channels than can be installed into a single logic analysis system frame, you can connect multiple 16900A and 16902A frames together in a multiframe logic analysis system.

Guidelines for Configuring a Multiframe System

- You must use the same speed networking card in all frames.
- If a frame has two LAN ports, Agilent recommends only one be used.
- Use the highest network speed available.
- If possible, use a switch (as opposed to a hub) to isolate traffic between frames from the rest of the network.



Setting Up Simple Multiframe Configurations

Simple multiframe configurations are useful when you are using one or more logic analysis systems in a variety of configurations where sometimes you are using them as distinct analyzers and sometimes you need to use them as a multiframe system to correlate a variety of buses.

Simple 100 Base-T Multiframe Configuration

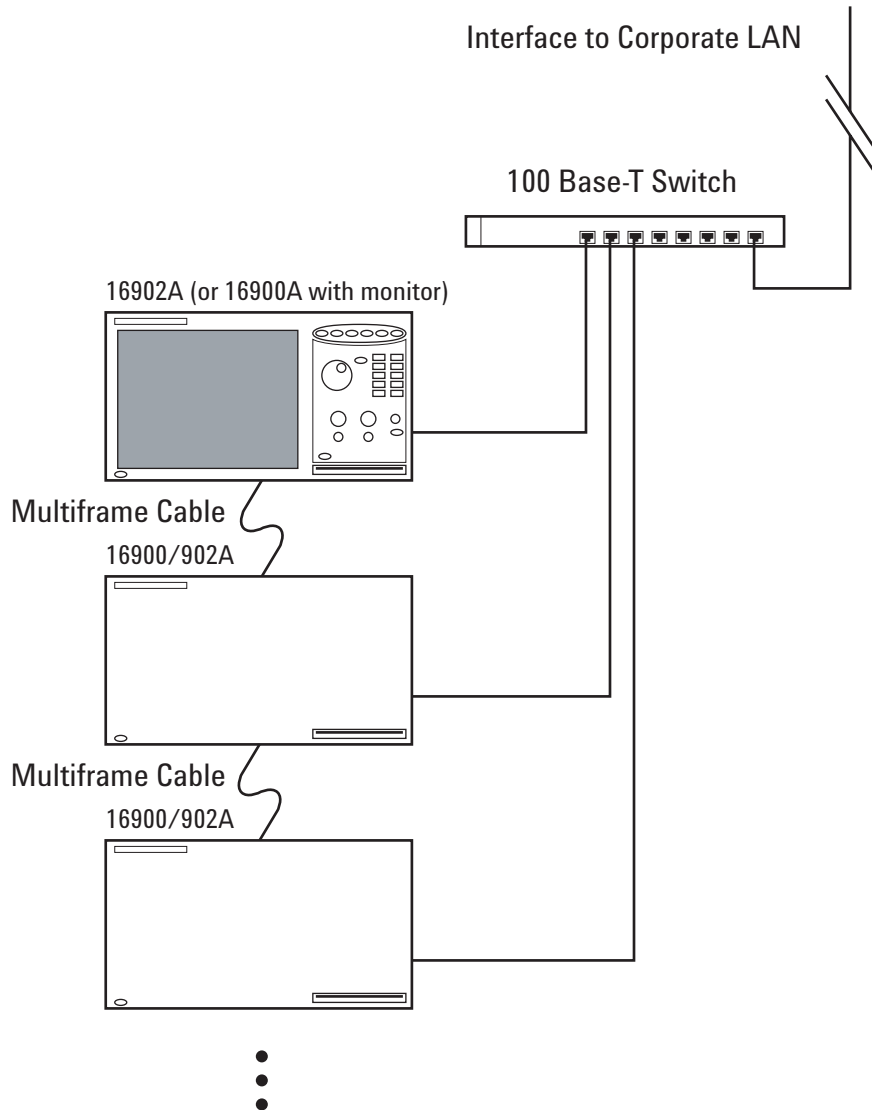

In the simple 100 Base-T multiframe configuration, all of the frames are connected to the network using their 100 Base-T LAN port.

Simple 1000 Base-T Multiframe Configuration

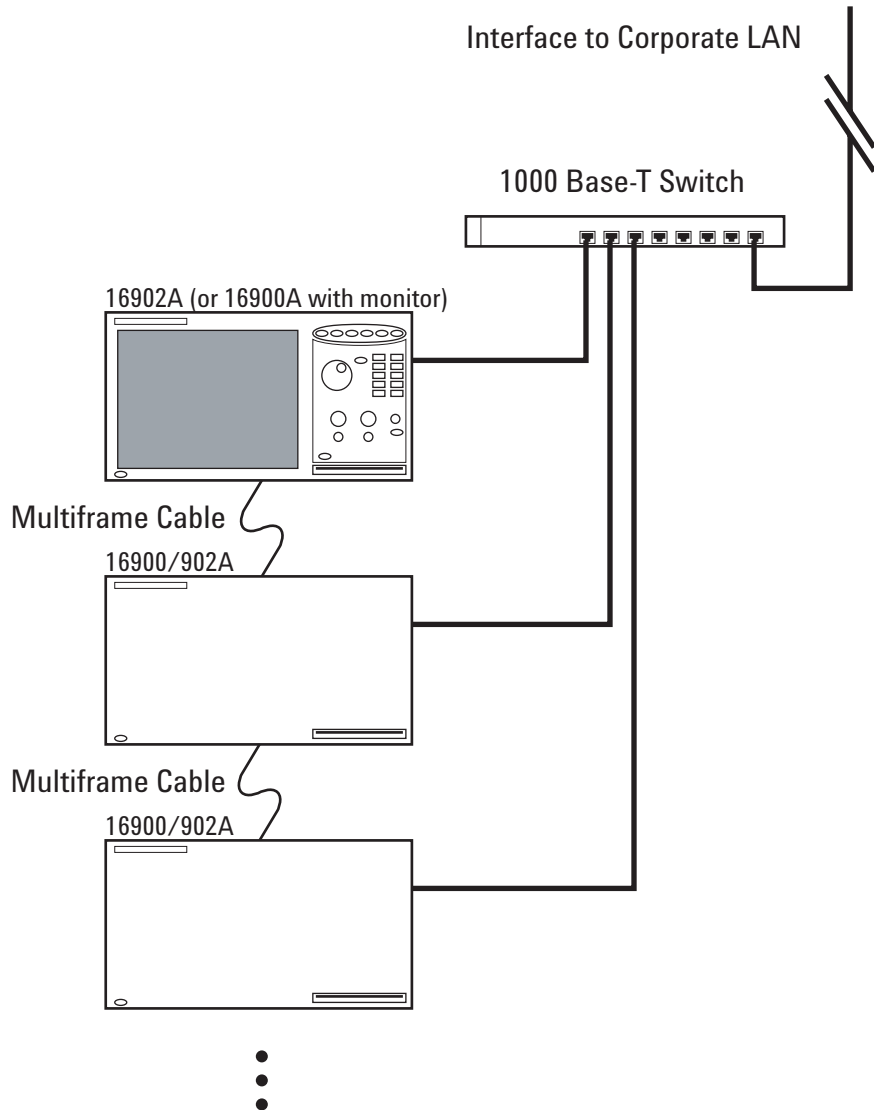

In the simple 1000 Base-T multiframe configuration, all of the frames are connected to the network using their 1000 Base-T LAN port.

Rules for Simple Multiframe Configurations

In addition to the earlier guidelines on [page 57](#):

- Choose one of the frames to run the *Agilent Logic Analyzer* application on. If you only run the application on one frame, all your configurations will be there (and will be easier to find). Also, there are I/O and license file advantages when the application is run on one frame (see “[Other Multiframe Configuration Notes](#)” on page 71).
- A network switch (as opposed to a hub) can be used to isolate traffic between frames and improve performance, but it is not required.

Creating Simple Multiframe Configurations

- 1 Make sure all frames are connected to the corporate LAN in the same way:
 - All frames should be members of the same Domain, or they should all be members of the same Workgroup. To get the frames properly connected to the LAN, see [Chapter 4](#), “First-Time Set Up,” starting on page 51 or “[To change network settings](#)” on page 85.
 - Use the same LAN port type on all frames to connect to the corporate LAN.
- 2 Power off all logic analysis system frames.
- 3 Connect multiframe cable(s) between the frames as shown.

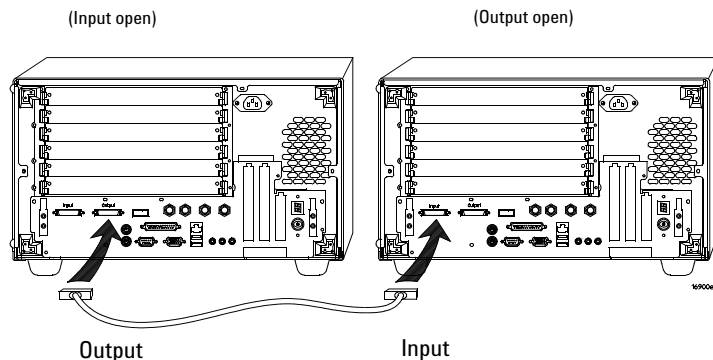

One frame's output is connected to the next frame's input, and so on.

5 Setting Up Multiframe Configurations

4 Power up all frames.

As the operating system loads, it will:

- Configure the connection to the corporate LAN.
- Start various services.
- Start the logic analyzer service.

5 Log in to the frame you chose to run the *Agilent Logic Analyzer* application on, and wait for the application to start.

NOTE

Depending on your multiframe connection topology, it may take several seconds for the *Agilent Logic Analyzer* application to start.

If the application starts without errors, and you see the multiframe system in the Overview window, you are ready to use the multiframe system.

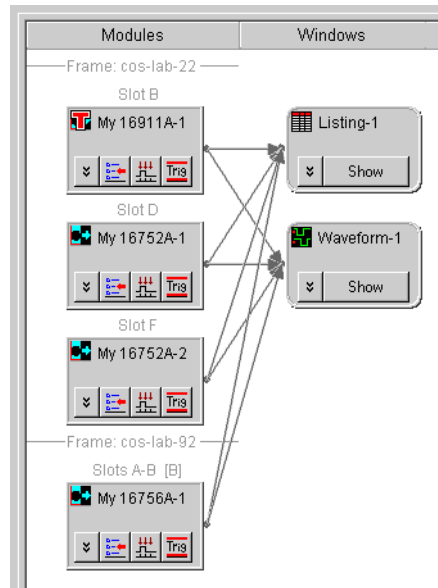

- 6 If you are not able to see the multiframe system in the Overview window, do the following:
 - a Exit the *Agilent Logic Analyzer* application.
 - b Power down all frames.
 - c Disconnect and reconnect the multiframe cables to all frames. Make sure the output of one frame is connected to the input of the next.
 - d Power up the frames.
 - e When all frames have been powered up, log in to the frame you chose to run the *Agilent Logic Analyzer* application on, and wait for the application to start.
- 7 If the multiframe system still does not appear in the Overview window, check these potential problems:
 - a Validate that you have properly configured the network setup on each of the frames. All frames must be able to communicate with each other over the multiframe cable and over the LAN.
 - b Validate that all frames can communicate with the corporate LAN.
 - c Validate that the firewalls are enabled on the corporate LAN connection and that they have the proper permissions (see ["To restore the logic analysis system firewall defaults"](#) on page 89). To test for firewall problems you could temporarily disable the firewall in the analyzers and repeat [step 6](#).

Remotely Controlling Simple Multiframe Systems

If you want to control the multiframe logic analysis system remotely, there are two options:

- Use one of the remote window utilities to remotely control the 16902A frame that runs the *Agilent Logic Analyzer* application. Choose from Remote Desktop, RealVNC, or NetOp. With this option:
 - You are not sending as much LAN traffic between the multiframe logic analysis system and your local PC.
 - Set up the remote options on your local PC to properly control the logic analysis system.

If you are not in the same building as the multiframe logic analysis system, you will typically want to use this option.

5 Setting Up Multiframe Configurations

- Run the *Agilent Logic Analyzer* application on your remote PC and connect to the multiframe system by going OnLine and Connecting to the 16902A frame. With this option:
 - Your performance may vary because analyzer data from all logic analysis frames must be sent over LAN to your locally running application.

Simple 2-Frame w/Crossover Cable Configuration

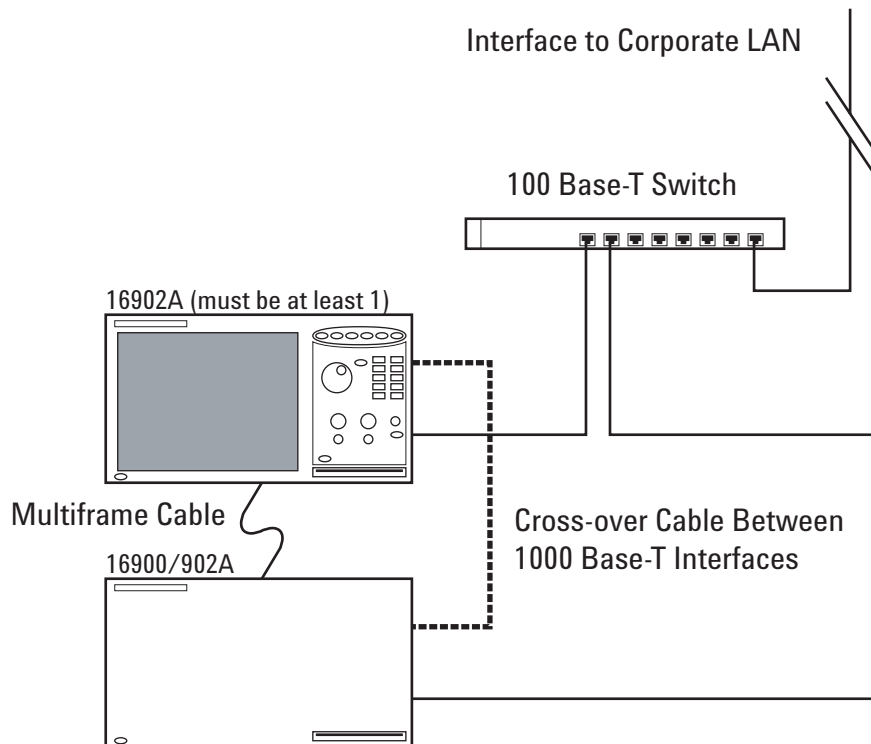

When you have only two frames in the simple 100 Base-T multiframe configuration (see [page 59](#)), you can gain performance by connecting a crossover cable between the frames' 1000 Base-T ports and configuring these ports with static IP addresses.

If you have a 1000 Base-T switch, use the simple 1000 Base-T multiframe configuration instead (see [page 60](#)).

Creating a Simple 2-Frame w/Crossover Cable Configuration

- 1 Set up the two frames in the simple 100 Base-T multiframe configuration by following the instructions in “Creating Simple Multiframe Configurations” on page 61.
- 2 If the *Agilent Logic Analyzer* application is running on one of the frames, exit the application.
- 3 Connect a special cross-over LAN cable between the two frames’ 1000 Base-T LAN ports.
- 4 Make sure the frames’ 1000 Base-T LAN ports are enabled, and manually set up static IP addresses for them in the network connection’s Internet Protocol (TCP/IP) Properties dialog. Use IP addresses in the link-local address range (169.254.xxx.xxx). Make sure the static IP address is different for each frame; for example, use 169.254.192.0 for one frame and 169.254.192.1 for the other. (Proper subnet masks, 255.255.0.0, are automatically filled-in.)

NOTE

Use static IP addresses on the frames’ 1000 Base-T LAN ports to greatly improve the *Agilent Logic Analyzer* application start up time.

- 5 After the static IP addresses for the frames’ 1000 Base-T LAN ports have been configured, wait about 10 seconds for the logic analyzer service to restart.
- 6 Start the *Agilent Logic Analyzer* application, and verify that the multiframe system appears in the Overview window.

Setting Up a Performance Multiframe Configuration

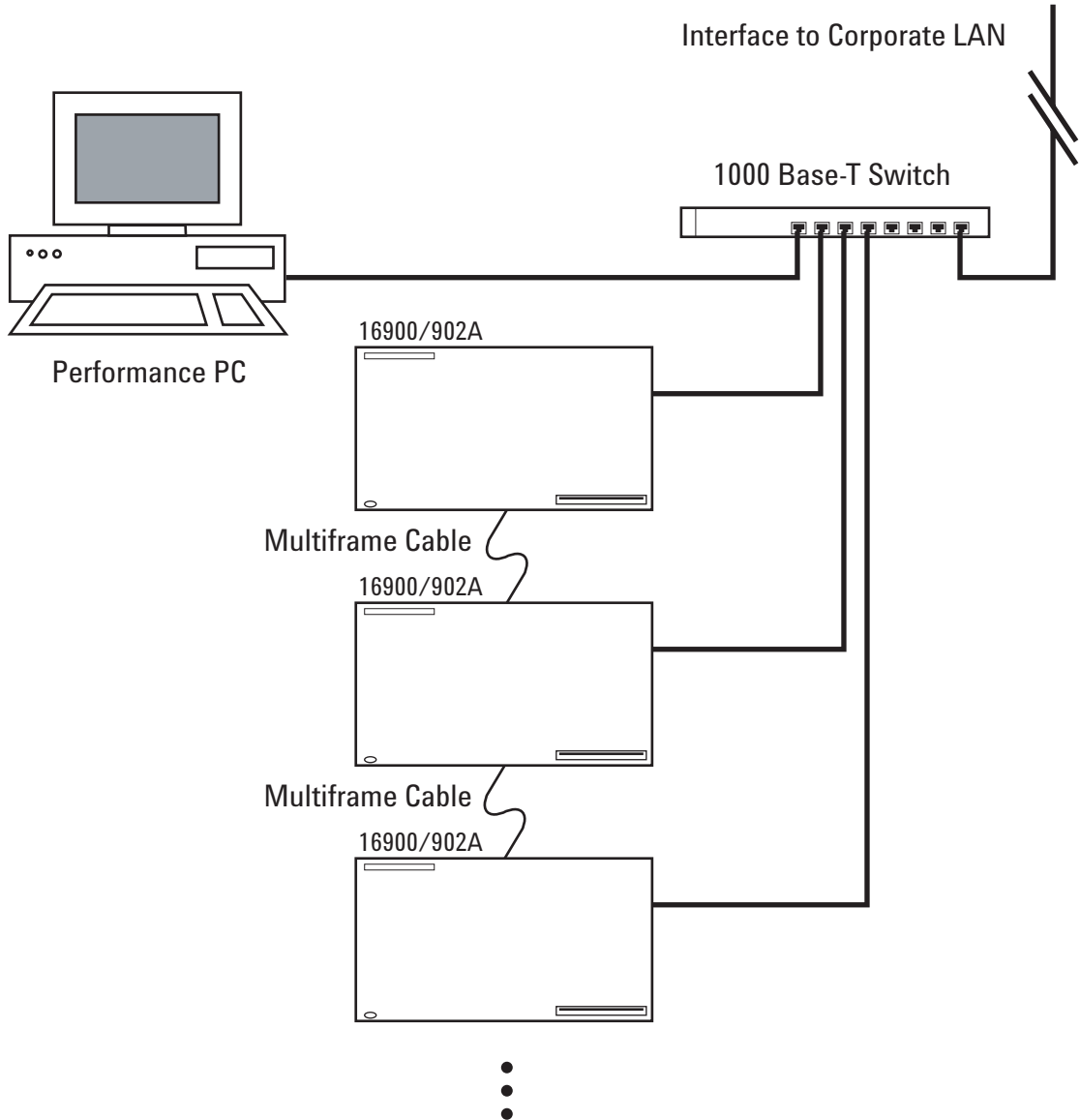

In the performance multiframe configuration, you run the *Agilent Logic Analyzer* application on a high-performance PC or server. This is useful if you are trying to maximize multiframe logic analysis system performance.

Rules for Performance Multiframe Configurations

In addition to the earlier guidelines on [page 57](#):

- You must use the 1000 Base-T LAN port in all frames; the 100 Base-T LAN ports must be disconnected, with no cable plugged-in
- The performance PC must have a 1000 Base-T LAN port.
- If the corporate LAN is not 1000 Base-T, or if the corporate LAN is heavily-used, use a 1000 Base-T switch (as opposed to a hub) to isolate multiframe system traffic.
- Frames can be a mix of 16900A and 16902A frames (or all one type).
- The *Agilent Logic Analyzer* application runs on the performance PC.

Creating a Performance Multiframe Configuration

- 1 Use a performance PC that can be dedicated to the multiframe setup.
- 2 Install the *Agilent Logic Analyzer* application on the performance PC. Make sure that the version you install on the performance PC is the same version as on all logic analysis system frames.
- 3 Make sure that all logic analysis system frames have a login screen and do not auto login upon power up.

Auto login occurs when the frames have been initialized with only one user, with no password, and are not connected to a Domain.

If any frame is in this state, add a second user, add a password, or add the frame to a Domain so that a login screen is presented at power up.

- 4 Connect the performance PC and all frames to the corporate LAN. To get the frames properly connected to the LAN, see [Chapter 4](#), “First-Time Set Up,” starting on page 51 or “[To change network settings](#)” on page 85.
 - Make sure all frames are connected to the corporate LAN and are recognized before continuing.
 - Because the *Agilent Logic Analyzer* application runs on the performance PC connected remotely to a frame, the frame’s front panel knobs and buttons are not functional.

5 Setting Up Multiframe Configurations

- 5 Power down all of the frames and the performance PC.
- 6 Connect multiframe cables between the frames as shown.

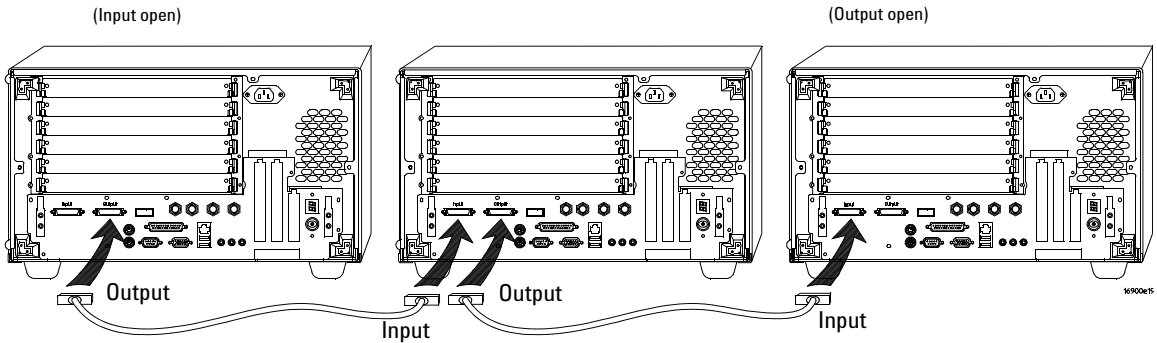

One frame's output is connected to the next frame's input. Connect multiple frames in sequence with the final frame having no output connected.

- 7 Power up all frames.

As the operating system loads, it will:

- Configure the corporate LAN connection.
- Start various services.
- Start the logic analyzer service.

- 8 Log in to one of the frames, and wait for the *Agilent Logic Analyzer* application to start.

If the application starts without errors, and the multiframe system appears in the Overview window, you are almost ready to use the multiframe system.

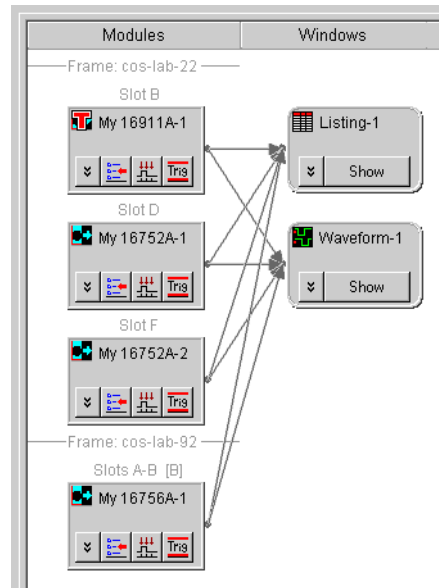

Exit the application, and continue on [step 10](#).

- 9 If you are not able to see the multiframe system in the Overview window on the frame, do the following:
 - a Exit the *Agilent Logic Analyzer* application.
 - b Power down all frames.
 - c Disconnect and reconnect the multiframe cables between all frames.
 - d Power up all frames.
 - e Log into one of the frames, and start the *Agilent Logic Analyzer* application again. If it starts properly, then exit the application.

- 10** Power up the performance PC, log in, start the *Agilent Logic Analyzer* application, and connect to one of the frames remotely:
 - a** When the application is starting and the Offline Startup Options dialog appears, click “Go Online...”.
 - b** In the Select System to Use dialog, click “Add System”.
 - c** In the Frame Host Name or IP Address dialog, enter the name of the frame, and click “OK”.
 - d** Select the system that was just added and click “Details...”.
 - e** In the Frame/Module Information dialog, click “Set as Auto-Connect”; then, click “OK”.

Now, each time you start the application on the performance PC it will auto-connect to that frame of the multiframe logic analysis system.

- 11** If you have trouble connecting to the frame, check these potential problems:
 - a** Verify that the multiframe logic analysis system appears in the Overview window when running the *Agilent Logic Analyzer* application on one of the frames. If it does, then simply exit the application. If it does not, then fix the problem on that frame first.
 - b** Verify that the firewalls on all frames are set up properly. This should allow the 16900 service to pass.
 - c** On the performance PC, do not block outbound traffic to port 16900.
 - d** The Refresh button in the Select System to Use dialog should show the status of the multiframe logic analysis system as “Available”.
 - e** Verify that network addressing is correct on all frames.

You can do this by running “ipconfig” in a command prompt window.

Remotely Controlling a Performance Multiframe System

If you want to control the performance multiframe system remotely, there is only one option:

- Use one of the remote window utilities to remotely control the performance PC. Choose from Remote Desktop, RealVNC, or NetOp. You will need to set up this service on your performance PC and your local PC.

Other Multiframe Configuration Notes

Some other things to be aware of when using multiframe configurations:

- The multiframe cable is used for time correlation, cross-triggering, and multiframe setup; all other inter-frame communication takes place over LAN.
- Network interfaces need to see a direct path to the DHCP server. Otherwise, power-up times will be slow. Use static IP addresses if a direct path to the DHCP server is not available.
- If you are using two or more Network Interface Cards (NICs) in a frame, each NIC must be wired to a separate subnet so that the NICs do not directly see each other (as suggested by the multiframe configuration diagrams in this chapter). If the NICs do directly see each other, networking will not work well.

I/O in Multiframe Configurations

- Trigger In/Trigger Out and the E5850A time correlation fixture must be connected to whichever frame the *Agilent Logic Analyzer* application connects to.
- If you are using the FPGA Dynamic Probe, you must connect the Xilinx parallel cable to the parallel port on the computer or frame that runs the *Agilent Logic Analyzer* application.

Licenses in Multiframe Configurations

If you are using probes, tools, or other application software that requires a license, install the licenses where the *Agilent Logic Analyzer* application runs:

- In the simple multiframe configurations, install licenses on the 16902A frame from which you run the *Agilent Logic Analyzer* application.
- In the performance multiframe configuration, install licenses on the performance PC.

5 Setting Up Multiframe Configurations



6 Using and Updating the Logic Analysis System

- To locate information on using the logic analyzer [74](#)
- To locate specifications and characteristics [75](#)
- To perform backups [77](#)
- To install software [77](#)
- To install interface cards [78](#)
- To replace the CPU battery [83](#)
- To power off the system [84](#)
- To change network settings [85](#)
- To change Windows Firewall settings [87](#)



To locate information on using the logic analyzer

Online Help

Go to online help for information on using your logic analyzer.

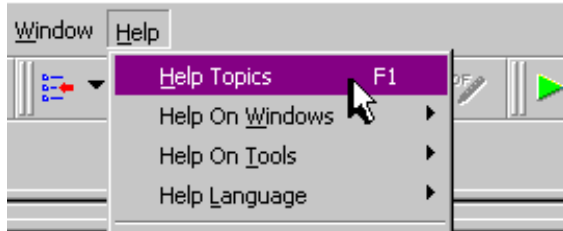

Getting Started

Use the tutorial in on-line help to get an overview of logic analyzer basics. The measurement examples show you the typical order of steps to set up and run a measurement.

Tips for Experienced Users

The *Quick Start for 16700-Series Users* provides experienced users of the 16700-series logic analysis system with tips on how to quickly become productive with the new 16900-series logic analysis system.

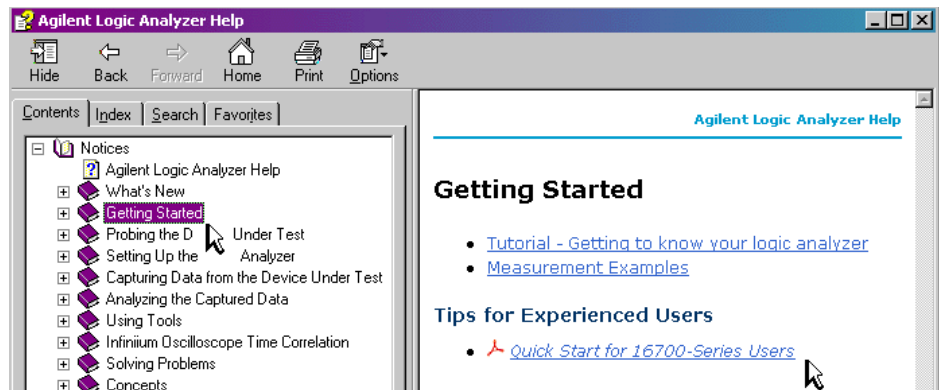

To locate specifications and characteristics

Electrical and Operating Environment Characteristics

The following operating characteristics are not specifications, but are typical operating characteristics for the Agilent 16900-series logic analysis systems.

Electrical Characteristics

Power Requirements	Frame(16900/902A): 115/230 Vac +/- 20%, 48-66Hz, 1300W Max Frame(16903A): 115/230 Vac +/- 20%, 48-66Hz, 900W Max CAT II (Line voltage in appliance and to wall outlet) Pollution degree 2
---------------------------	--

Environmental Characteristics (Operating)

Temperature	Instrument (16900A & 16902A): 0° to + 40° C (+32° to +104° F) Instrument (16903A): 0° to + 50° C (+32° to +122° F) Disk Media: 10° to + 40° C (+50° to +104° F) Probes/cables: 0° to + 65° C (+32° to +149° F)
Altitude	3,000 m (10,000 ft)
Humidity	Relative humidity 8 to 80% at 40° C (104° F). Avoid sudden, extreme temperature changes which could cause condensation on the circuit board. For indoor use only.



Trigger In

The Trigger In connector is 5.5V Max pk and DC, CAT I (line isolated).



Clock In

The Clock In connector is 5.5V Max pk and DC, CAT I (line isolated).

More Specifications and Characteristics

More specifications and characteristics for your instrument and measurement modules are in the online help. To find them go to:

- 1 Click **Help>Help Topics**.

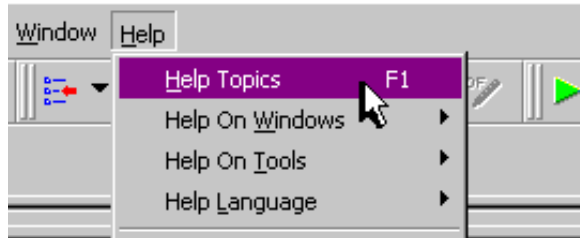

- 2 Click **Reference>Specifications and Characteristics**.

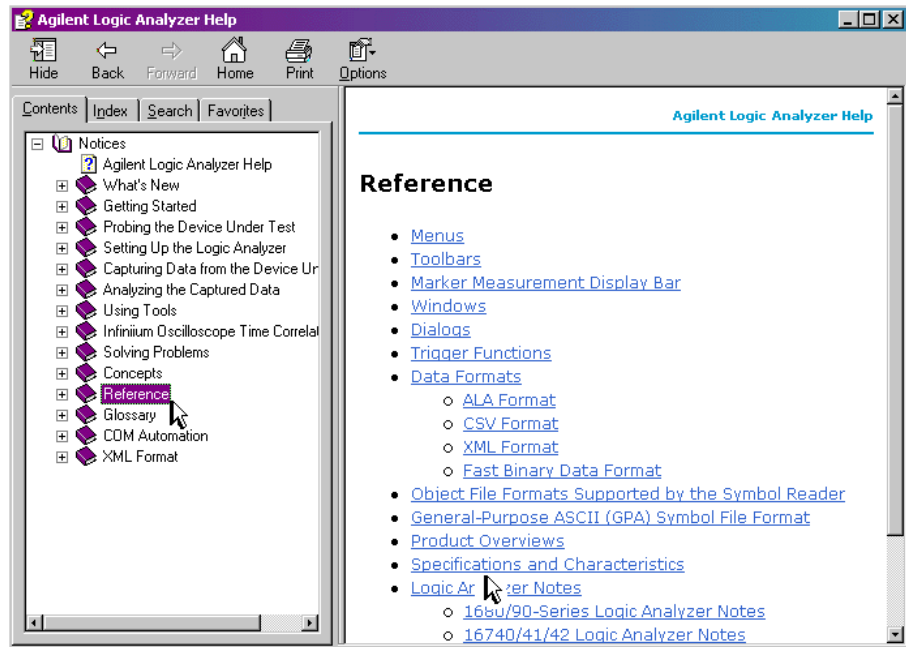

To perform backups

Back up your information regularly to keep your archived data and files up-to-date. Use the Backup utility in Windows XP and back up to CD-Rs or to another machine.

To install software

Agilent Logic Analysis System Software

The Agilent 16900-series logic analysis systems are shipped with software already installed, including any licensed optional products that you may have purchased. The licensing process (described below) has been performed and the (*.lic) license file is in place.

To upgrade the logic analyzer software insert a product CD and click **INSTALL PRODUCTS>Install Logic Analyzer**. Note that newer versions of the Logic Analyzer software will automatically uninstall the previous version as a step in the upgrade. (User files in the "Documents and Settings" tree are not affected.)

To install the logic analyzer software onto your PC for offline processing, insert the product CD into your PC drive, click **INSTALL PRODUCTS>"Install Logic Analyzer**.

Logic analyzer product software can be downloaded from the web at:
http://www.agilent.com/find/16900_SW_Download

Logic analyzer product CDs can be ordered from this web-site:
<http://software.cos.agilent.com/LogicAnalyzerSW>

To be notified when software upgrades are available for downloading from the web, please sign up for e-mail notifications at:
<http://www.agilent.com/find/emailupdates>

Optional Products

If applicable, follow the instructions on the entitlement certificate that came with your purchase to enable the optional tool.

To install interface cards

CAUTION

Electrostatic discharge can damage electronic components. Use grounded wrist straps and mats when performing this procedure.



The following instructions show you how to properly remove/replace the CPU tray and install PCI cards.

- 1 Power down the system and disconnect the power cable before installing interface cards.
- 2 Remove the cover.
 - a Remove 3 screws from the back panel using a T-10 screwdriver.
 - b Remove the handle using a T-15 screwdriver to remove the 2 screws.
 - c Slide the cover back and up to remove.

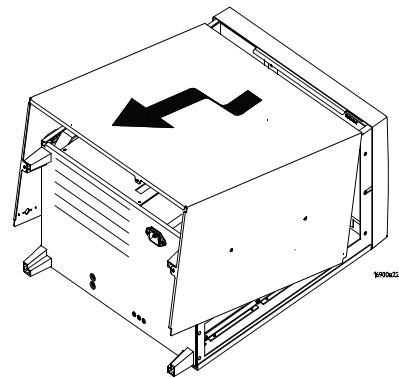
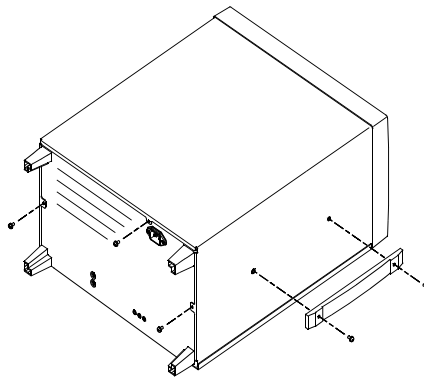

CAUTION

When reinstalling the handle assembly, ensure that the screws are torqued to 2.372 Newton meters (21 inch pounds) so that they do not work themselves loose.

- 3** Disconnect cables from the module interface board.
- a** If you have a 16900A or 16902A:

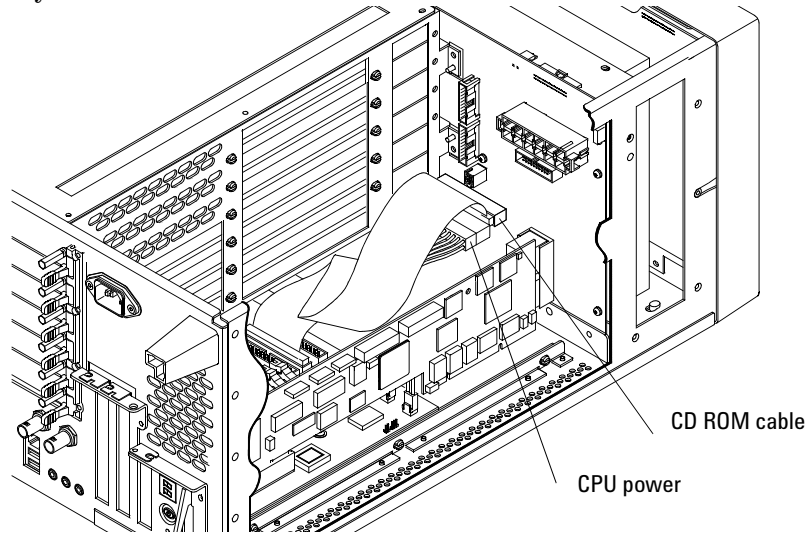

- b** If you have a 16903A:

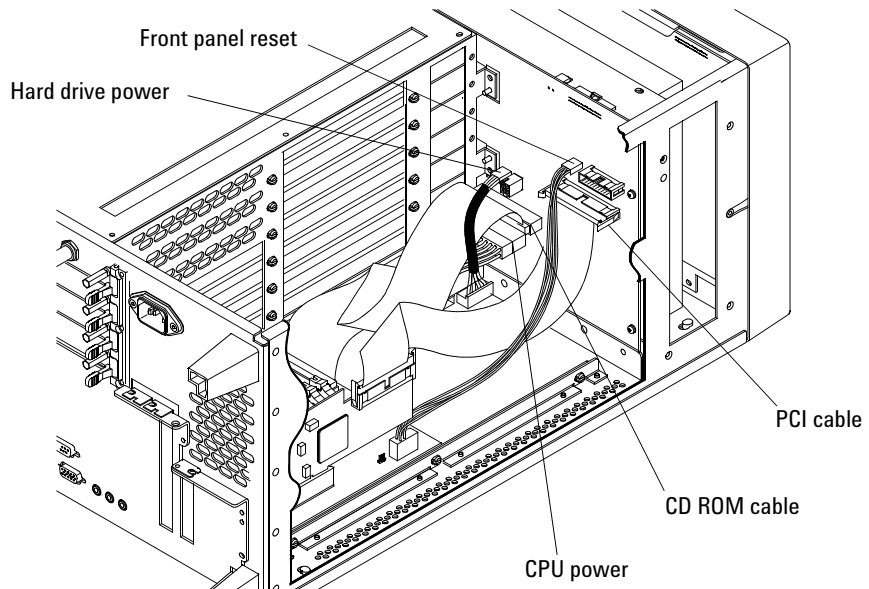

6 Using and Updating the Logic Analysis System

- 4 Remove screws from the back of the CPU tray using a Torx T-10 screwdriver.

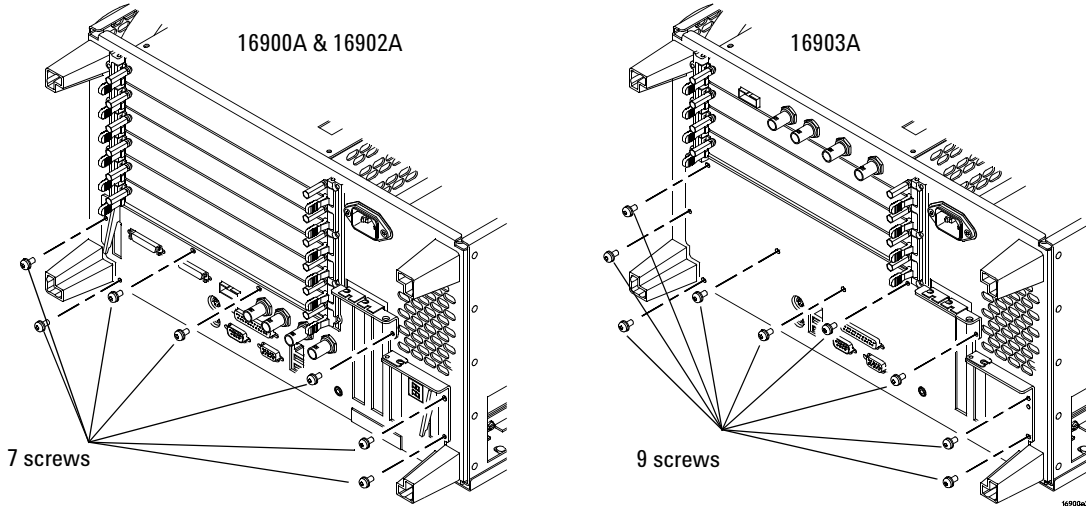

- 5 Remove the CPU tray.

- a If you have a 16900A or 16902A, use the tray lever to disconnect the CPU board from the module interface board then slide the tray out being careful not to catch the loose cables on anything.

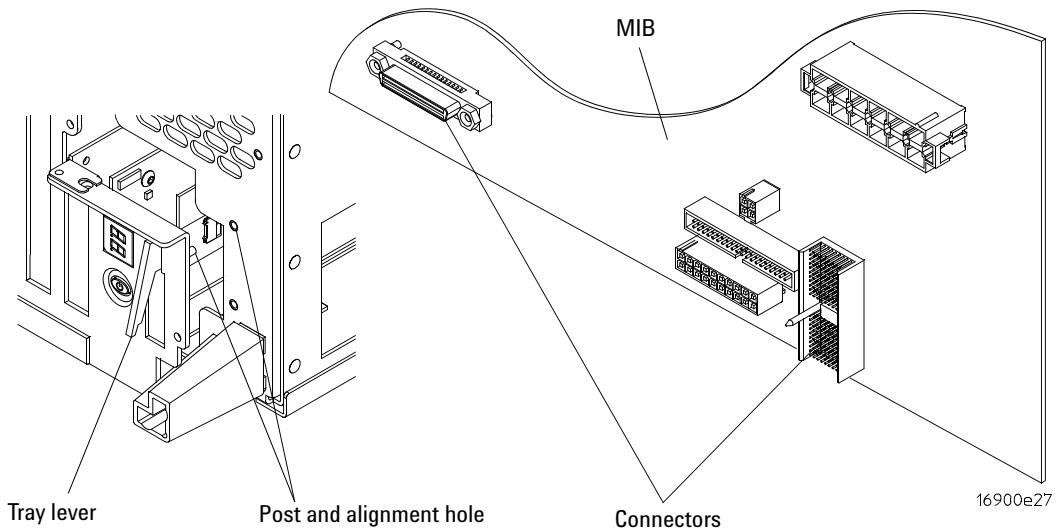

- b** If you have a 16903A, slide the tray out being careful not to catch the loose cables on anything.
- 6** For the PCI card location you will be using, remove the screw securing the filler panel, swing the tall-slot plate out of the way if necessary, and remove the filler panel.

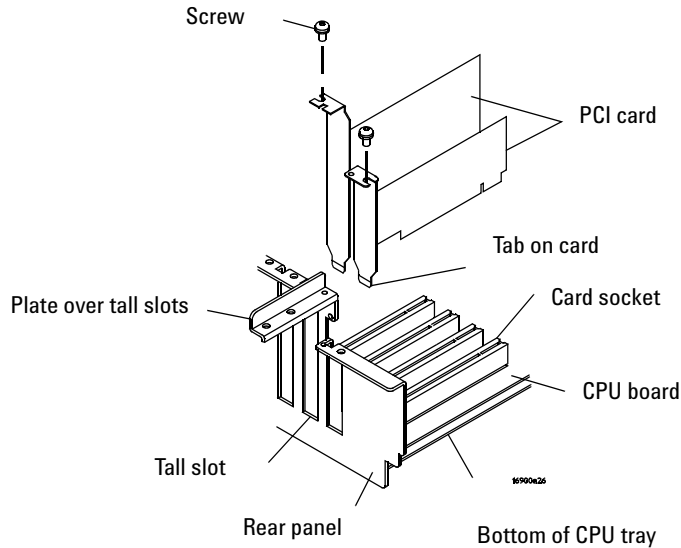

- 7** Insert the PCI card into the appropriate slot:
 - a** Ensure that the tab at the bottom of the card is aligned with the slot in the bottom of the CPU tray between the CPU board and the rear panel.
 - b** Press the card securely into the socket on the CPU board.
 - c** For cards in a tall slot, swing the plate back into place.
 - d** Secure the PCI card with the screw.
- 8** Slide the CPU tray back into the frame.
 - a** If you have a 16900A or 16902A ensure that the connectors between the CPU board and module interface board are properly seated. First align the posts and holes then use the tray levers to push the tray fully into place (see the figure in [step 5a](#)).
 - b** If you have a 16903A, slide the CPU tray into the frame.

6 Using and Updating the Logic Analysis System

- 9 Insert and tighten the screws shown in [step 4](#).
- 10 Reconnect the CPU cables shown in [step 3](#).

1 Gbit LAN Card

If you ordered a 1 Gbit LAN card with your frame (option 014) it will already be installed. If you order the 1Gbit LAN card separately (as model E5860A) you will need to install them following the instructions beginning on [page 78](#). To order a 1 Gbit LAN card go to: <http://www.agilent.com/find/contactus>.

To replace the CPU battery

- 1 Power down the system and disconnect the power cable before replacing the CPU battery.

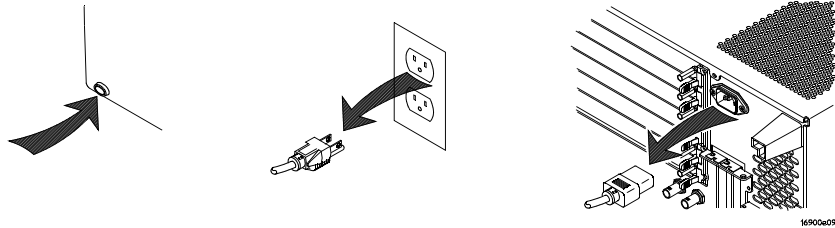

- 2 Remove the CPU tray following steps 1-4 on [page 78](#).
- 3 Using a 1/8 inch flat-blade screwdriver, gently pry the battery from the battery receptacle.

CPU Battery
(positive side up)

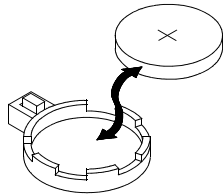

Battery Receptacle

- 4 Insert a new battery (CR2032 3V lithium) into the battery receptacle.
- 5 Re-install the CPU tray following steps 7-9 on [page 81](#).

To power off the system

You can power off the logic analysis system using Windows Shutdown or a short press of the power button.

NOTE

When powering off the logic analysis system, wait until the fans stop turning (about 15 seconds) before turning the logic analysis system back on. This ensures that internal circuitry restarts in a known state.

Using the Windows Shutdown

On the logic analysis system desktop click **Start> Shut Down** or if you are running remote desktop, click **Start> Settings> Windows Security> Shut Down**. This:

- Closes all programs that are running.
- Writes all data to the disk.
- Turns off the power supply.
- If the system is unplugged while it is off and then plugged back in, the system will not power on until the power button is pressed.

Using a Short Press of the Power Button

Pressing the power button on the logic analysis system for a short time (less than 2 seconds):

- Closes all programs that are running.
- Writes all data to the disk.
- Turns off the power supply.

If the power button on the Remote Desktop is depressed for a short time (less than 2 seconds or so), a message on the logic analysis system screen (not on the remote desktop) will pop up asking if you really want to power down. Clicking the 'yes' button results in the above events. Clicking 'no' will prevent the shutdown and not answering the dialog box (neither clicking "Yes" or "No") will have no effect. Further short presses on the power button will have no effect.

Using a Long Press of the Power Button

CAUTION

Only use a long press of the power button when the logic analysis system is unresponsive to Windows Shutdown or a short press of the power button.

Pressing the power button for more than 4 seconds will power the system down abruptly:

- Programs that are running will not be shut down. Any data that has not been written to the disk will be lost.
- Turns off the power supply.
- If the system is unplugged while it is off and then plugged back in, the system will not power on until the power button is pressed

Unplugging the Power Cord or Power Loss

CAUTION

Only unplug the power cord when the logic analysis system is unresponsive to all other methods for powering off the system.

Unplugging power or a power loss is similar to the long press of the power button with one exception:

- When the system is plugged back in, it will power up and boot into Windows.

To change network settings

To make network changes after the first-time power up:

- To change from a workgroup to a domain or vice versa, click **Start** then right click on **My Computer** and select **Properties**. Select the Computer Name tab and click **Change**.
- To change network connection properties, click **Start>Control Panel>Network Connections**. Select the connection you want to change and click **Change settings of this connection**.

6 Using and Updating the Logic Analysis System

For more information on changing network settings, refer to the Windows XP online help.

To change Windows Firewall settings

When 16900-series logic analysis systems are shipped from the factory, the Windows Firewall is enabled and set up with the exceptions required by the logic analysis system.

To give other applications/ports access through the firewall

For example, you may need to change firewall settings in order to:

- Use NetOp to remotely control the logic analysis system.
- Use RealVNC to remotely control the logic analysis system.

To change firewall settings to give other applications/ports access:

- 1 From the Windows Start menu, choose **Start>Control Panel**.
- 2 In the Control Panel window, open **Windows Firewall**.

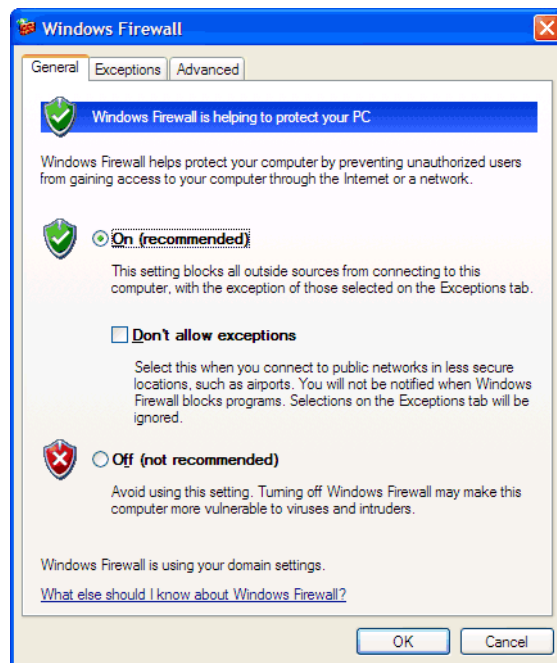

- 3 In the Windows Firewall dialog, click the **Exceptions** tab.

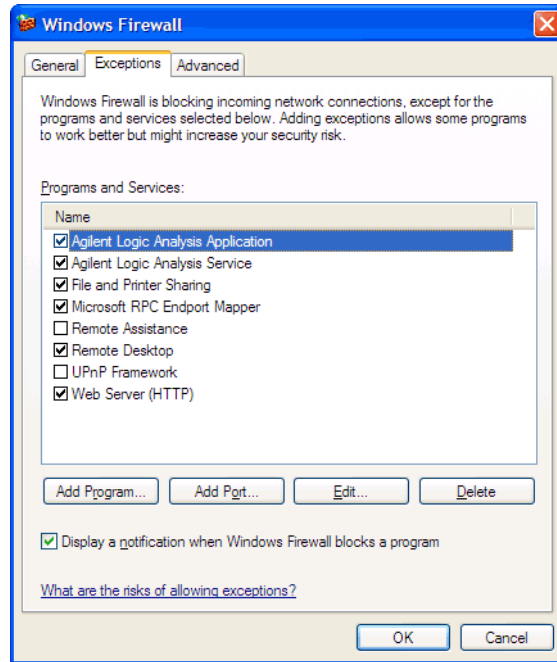

- 4 In the Exceptions tab, if the program or service is listed, check its box to enable it; otherwise, click **Add Program...** to give unlisted applications permission to penetrate the firewall, or click **Add Port...** to give unlisted ports access through the firewall.

Refer to the application's documentation for information on port numbers or other firewall setup information.

NOTE

Note that there are separate Windows Firewall profiles: Domain for when the computer has domain membership, and Standard for when the computer has workgroup membership. If you change the type of membership, any changes you made to the Windows Firewall settings will have to be made again.

To restore the logic analysis system firewall defaults

- 1 From the Windows Start menu, choose **Start>Control Panel**.
- 2 In the Control Panel window, open **Windows Firewall**.

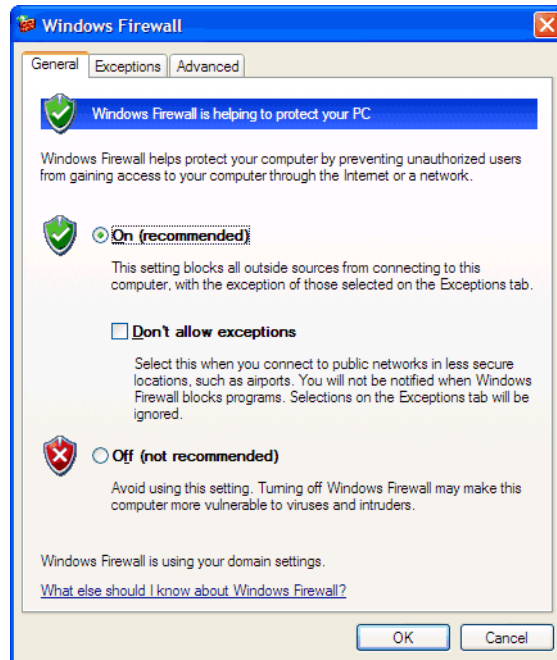

- 3 In the Windows Firewall dialog, click the **Advanced** tab.

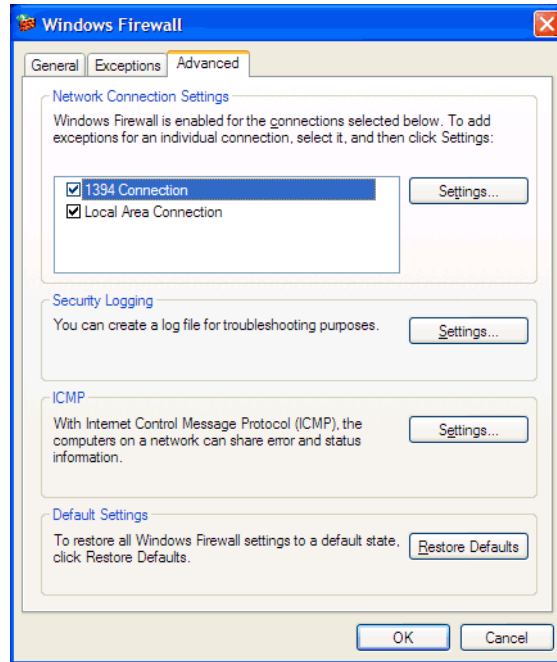

- 4 In the Advanced tab, click **Restore Defaults** to restore the default Windows Firewall settings.
- 5 In the confirmation dialog, Click **Yes**.
- 6 Click **OK** to close the Windows Firewall dialog.
- 7 From the Windows Start menu, choose **Start>Run**; then, enter or select the file “C:\Program Files\Agilent Technologies\Logic Analyzer\agFirewSP2.wsf”, and click **OK**.

The logic analysis system firewall defaults enable the following exceptions:

- Agilent Logic Analysis Application program.
- Agilent Logic Analysis Service program.
- File and Printer Sharing.
- Microsoft RPC Endport Mapper TCP port.
- Remote Desktop service.
- Web Server (HTTP) port.

The logic analysis system firewall defaults also enable the following ICMP (Internet Control Message Protocol) settings:

- Allow incoming echo request.
- Allow outgoing destination unreachable.
- Allow outgoing time exceeded.

NOTE

Note that there are separate Windows Firewall profiles: Domain for when the computer has domain membership, and Standard for when the computer has workgroup membership. When you restore the logic analysis system firewall defaults, the defaults for both profiles are restored.

6 Using and Updating the Logic Analysis System



7 Solving Problems

Running Self-Tests	94
If the logic analysis system powers itself down	95
If the Power LEDs do not come on	96
If you get a registry error and the system won't boot	96
If you can't write/read CDs	96
If there are multiframe connection problems	97
If there are network connection problems	99
Using the System Recovery Software	100
Contacting Agilent Service/Support	100



Running Self-Tests

- 1 In the Agilent logic analyzer application, click **Help>Self Test**.

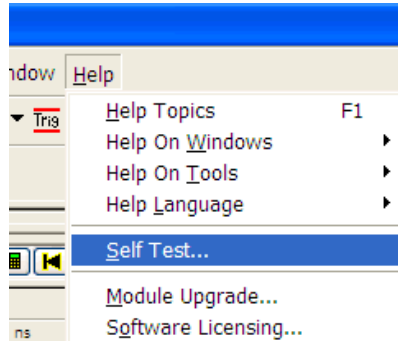

- 2 In the analysis system Self Test dialog, double click on the test you want to run.

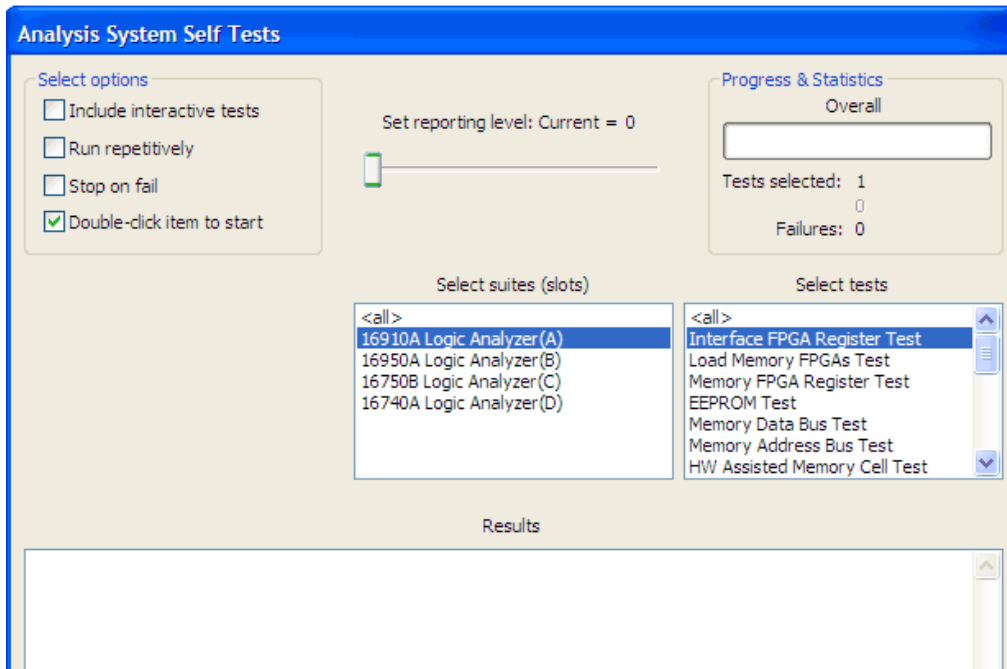

If the logic analysis system powers itself down

16900A and 16902A logic analysis systems

The power LEDs on the frame help to figure out why a frame has powered itself down. For safety purposes, when any of these LEDs are lit the frame will not power back up until the power cord has been disconnected and then reconnected.

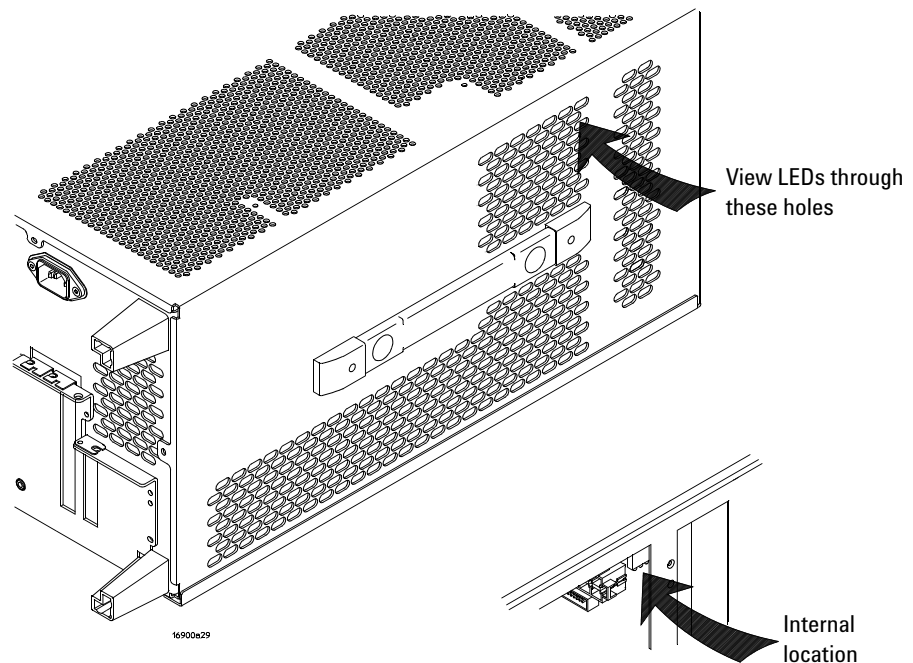

The colors indicate:

- Green - 500 W power supply failure.
- Yellow - 700 W power supply failure.
- Red - fan failure or 'overtemp'.

For any of the above conditions, go to <http://www.agilent.com/find/contactus> to contact your local service representative.

All 16900-series logic analysis systems

If the system warns you it is powering down before it powers down, the dialog will describe the problem (such as a fan/overtemp problem). If the logic analysis system just powers down, it is likely a power supply problem.

If the Power LEDs do not come on

On the 16900A and 16902A frames, if the lights do not come on and if the system powers up momentarily when you plug it in, make sure the power buttons haven't become jammed or stuck in the pushed in position.

If you get a registry error and the system won't boot

When powered off unexpectedly (for example, with a long press of the power button or a power loss), Windows XP may not flush all system information to disk and is vulnerable to problems. When you power back on you may get a "Registry Error" and the system won't boot. If this happens you will need to restore from the system install CD-ROM.

It is best to keep regular backups of your data and use proper power down procedures. If you have data that was not backed up that you need to try to save:

- 1 Physically remove the disk drive.
- 2 Mount it under another XP system.
- 3 Move the data to the boot disk until you can restore the operating system.

If you can't write/read CDs

- ✓ Ensure that Windows recognizes the drive. Click the **Start** button and then click **My Computer**. If the drive is not listed, perform a full scan with your antivirus software to check for and remove viruses. Viruses can sometimes prevent Windows from recognizing the drive.
- ✓ The CD drive must be parallel to the ground when writing to disk. CDs may not be readable in any CD-ROM drive if it was not.

- ✓ If a CD fails, clean it by wiping it off with a clean dry rag and then try again. If it continues to fail, insert another CD to eliminate the possibility that the original CD is defective.

The logic analysis system has a DVD-ROM & CD-R/RW combination drive with the following features:

- 24X Speed CD-R Writing.
- 24X Speed CD-RW Writing.
- 24X Speed CD-ROM Reading.
- 8X Speed DVD-ROM Reading.
- Can read DVD-RAM, DVD-R and DVD-RW.
- Buffer Under Run Protection.
- Writing Method:
 - Disc at Once.
 - Session at Once.
 - Track at Once.
 - Multi-Session.
 - Fixed/Variable Packet Writing.

If there are multiframe connection problems

All 1Gbit LAN cards in a multiframe set up must be set with the same Jumbo Frames setting. Also, if a switch/hub is used, you must ensure that it supports the same size Jumbo Frame setting. If all 1Gbit LAN cards are not set with the same Jumbo Frames setting, you might get error messages indicating so.

- One or more of the frames is not completely initialized yet... Please wait a few seconds.

To check the Jumbo Frames setting:

- 1 Choose **Start>Control Panel**. In the Control Panel window, open **Network Connections**.

7 Solving Problems

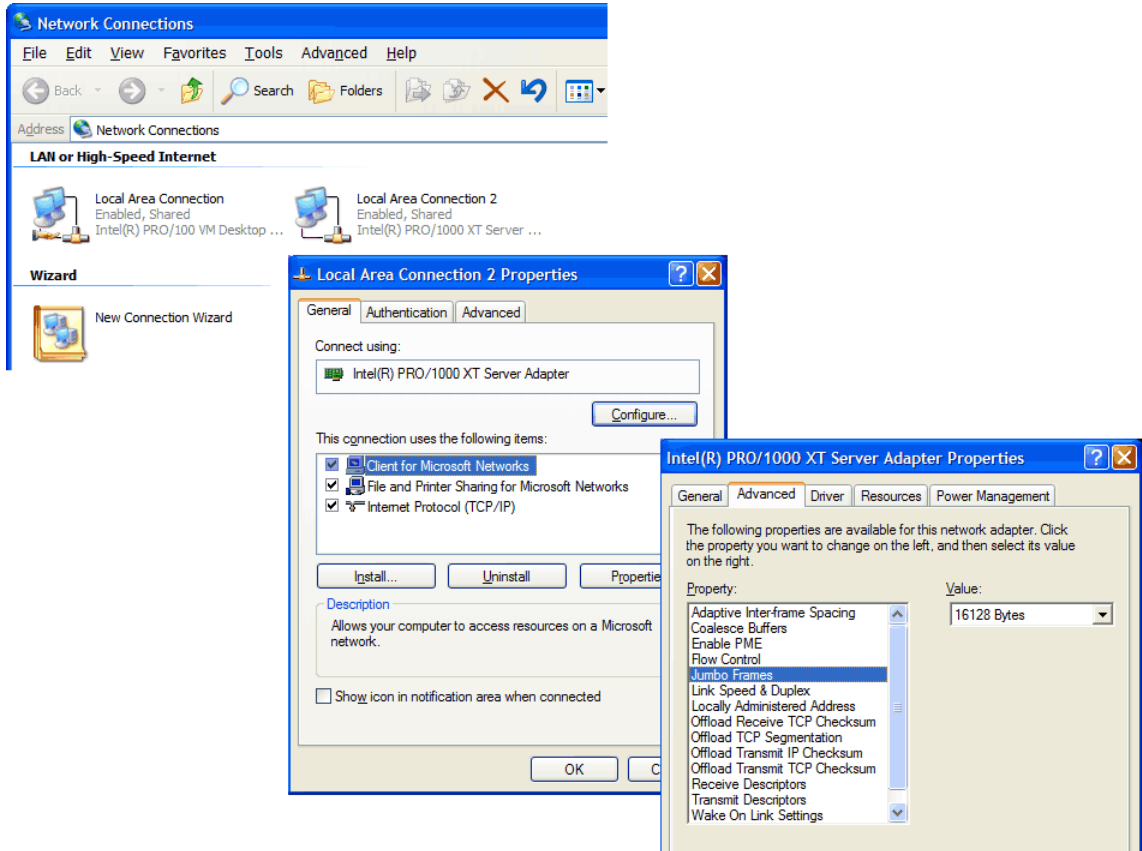

- 2 Right-click on the LAN connection and select **Properties**.
- 3 Click on **Configure** and then select the **Advanced** tab.
- 4 Select **Jumbo Frames** and the **Value**.

If there are network connection problems

See the “Network Troubleshooting Guide” topic in the *Agilent Logic Analyzer* application’s online help. Briefly:

- The Windows Firewall must be set to allow access to the “Agilent Logic Analysis” service in order use remote and multiframe connections (see [“To restore the logic analysis system firewall defaults”](#) on page 89).
- The Windows Firewall must be set to respond to the following ICMP (Internet Control Message Protocol) requests in order to use remote and multiframe connections:
 - Allow incoming echo requests.
 - Allow outgoing destination unreachable.
 - Allow outgoing time exceeded.

(See [“To restore the logic analysis system firewall defaults”](#) on page 89.)

- The link activity light must be on; If these LEDs are not on, the LAN segment may be dead.
- If connecting two logic analysis systems directly together (that is, no hub or switch between them), make sure you are using a special cross-over cable.

If your IP address is in the same subnet as a working computer’s (use “ipconfig /all | more” to view IP addresses on machine in question), it is possible that your network administrators have denied access to any resources if the computer is not in the domain. In this case, you need to add the computer (logic analysis system) to the domain.

Using the System Recovery Software

Restoring your system software might be necessary for the following reasons:

- Hard drive failure.
- Virus in the system or unstable system.
- Intentional disk clean - for example if you are passing the system to another team or returning it to a rental company and you do not want any data left on it.

You will need to have a keyboard and mouse connected. Follow the instructions provided with the recovery CD to restore your system software.

CAUTION

Running the recovery disks will reformat your hard drive. All data files and programs will be overwritten. Save your data to CD or to another machine before performing this procedure.

Contacting Agilent Service/Support

To locate a sales or service office near you, go to <http://www.agilent.com/find/contactus>.



A Safety Notices

This apparatus has been designed and tested in accordance with IEC Publication 1010, Safety Requirements for Measuring Apparatus, and has been supplied in a safe condition. This is a Safety Class I instrument (provided with terminal for protective earthing). Before applying power, verify that the correct safety precautions are taken (see the following warnings). In addition, note the external markings on the instrument that are described under "Safety Symbols."

Warnings

- Before turning on the instrument, you must connect the protective earth terminal of the instrument to the protective conductor of the (mains) power cord. The mains plug shall only be inserted in a socket outlet provided with a protective earth contact. You must not negate the protective action by using an extension cord (power cable) without a protective conductor (grounding). Grounding one conductor of a two-conductor outlet is not sufficient protection.
- Only fuses with the required rated current, voltage, and specified type (normal blow, time delay, etc.) should be used. Do not use repaired fuses or short-circuited fuse holders. To do so could cause a shock or fire hazard.
- If you energize this instrument by an auto transformer (for voltage reduction or mains isolation), the common terminal must be connected to the earth terminal of the power source.
- Whenever it is likely that the ground protection is impaired, you must make the instrument inoperative and secure it against any unintended operation.
- Service instructions are for trained service personnel. To avoid dangerous electric shock, do not perform any service unless qualified to do so. Do not attempt internal service or adjustment unless another person, capable of rendering first aid and resuscitation, is present.



A Safety Notices

- Do not install substitute parts or perform any unauthorized modification to the instrument.
- Capacitors inside the instrument may retain a charge even if the instrument is disconnected from its source of supply.
- Do not operate the instrument in the presence of flammable gasses or fumes. Operation of any electrical instrument in such an environment constitutes a definite safety hazard.
- Do not use the instrument in a manner not specified by the manufacturer.
- To optimize your comfort and productivity, it is important that you set up your work area correctly and use your equipment properly. Refer to http://www.agilent.com/quality/Working_In_Comfort.pdf for set-up and use recommendations
- Position equipment so that it is not difficult to disconnect the power cord.

To clean the instrument

If the instrument requires cleaning:

- 1 Remove power from the instrument.
- 2 Clean the external surfaces of the instrument with a soft cloth dampened with a mixture of mild detergent and water.
- 3 Make sure that the instrument is completely dry before reconnecting it to a power source.

Safety Symbols



Instruction manual symbol: the product is marked with this symbol when it is necessary for you to refer to the instruction manual in order to protect against damage to the product.



Hazardous voltage symbol.



Earth terminal symbol: Used to indicate a circuit common connected to grounded chassis.

Index

Numerics

- 16750/51/52A/B, installation, 23, 45
- 16753/54/55/56A installation, 28
- 16760A, installation, 33
- 16910/11A installation, 38
- 16950A, installation, 28
- 548XX series oscilloscope, 16

A

- accessories
 - included, 4
 - optional, 4
- administrator, 52
- administrator account, 56
- Agilent web
 - probes, 18
 - service/support, 95, 100
- air circulation, 13, 22
- altitude, 75
- antivirus, 14, 56

B

- backup, 77

C

- cable
 - flying lead, 4
 - multiframe, 4
- cards, measurement, 3
- caution
 - electrostatic discharge, 20, 78, 85
- CD
 - features, 97
 - product software, 77
 - write/read problems, 96
- change network settings, 85
- characteristics, 75, 76
- cleaning the instrument, 101

- comparison of models, 3
- computer name, 54
- connect
 - keyboard, 12
 - LAN, 14
 - logic analyzer probes, 18
 - monitor, 12
 - mouse, 12
 - power, 13
 - printer, 15
 - time correlation fixture, 16

- connection
 - problems, 97
- connection, high speed, 54
- contact information, 100
- cooling, 13, 22
- CPU
 - tray removal, 78
- CPU battery replacement, 83
- cross-triggering, 71

D

- debugging network, 99
- disk
 - clean/reformat, 100
 - read error, 96
- display resolution, 3
- domain, 52, 54
- DVD-ROM, 96

E

- E5850A time correlation fixture, 16, 71
- ejector levers, 20
- electrical characteristics, 75
- electrostatic discharge, 20, 78, 85
- environmental characteristics, 75

F

- filler panel removal, 20

- firewall, 14, 56
 - changing settings, 56, 87
- flowchart, 5
- flying lead cable, 4
- frames
 - multiple, 3

G

- getting started, 5, 74
- grounding, 20, 78, 85

H

- hard drive, 100
- hardware, setup, 11
- help, 74
- high-speed connection, 54
- humidity, 75

I

- ICMP settings, 91
- Infinium 548XX series oscilloscope, 16
- Infinium time markers, 16
- install
 - interface cards, 78
 - measurement modules, 20
 - software, 77
- interface cards, 78
- internet, 54
- inverse assemblers, 77

J

- jumbo frames setting, 97

K

- keyboard, 4, 12

Index

L

LAN, 12, 54
 connect, 14
LAN card, 4, 82
LEDs, 95, 96

M

measurement modules, 3
 16740/41/42A, 16750/51/52A/B, 23, 45
 16753/54/55/56A, 28
 16760A, 33
 16910/11A, 38
 16950, 28
 general installation, 20
 screw replacement, 19, 20
minimum space for cooling, 13
model comparison, 3
monitor, 3, 12
mouse, 4, 12
multiframe cable, 4
multiframe configuration, 57
 other notes, 71
 performance, 66
multiple frames, 3

N

network
 adding logic analyzer, 52
 connection decision, 52
 debugging, 99
network connection problems, 99
network settings, 85

O

online help, 74
optional accessories, 4
optional tools, 77
ordering
 thumb screws, 19, 20
oscilloscope
 Infiniium 548XX series, 16
 time correlation, 16
overheating, 13
overview, 3

overview flowchart, 5

P

password, 54
PCI
 cards, 78
 LAN card, 82
 slots, 78
performance multiframe configuration, 66
 considerations when running, 70
power
 connect, 13
 LEDs, 95
 problems, 95
 requirements, 75
 turning off, 84
 turning on, 51
printer, 15
probes, 4, 18

Q

quick start, 74

R

read problems, CD, 96
recovery procedures, 100
registry error, 96
remove
 CPU tray, 78
 filler panels, 20
replace
 CPU battery, 83
restoring system, 100
running self tests, 94

S

safety
 notices, 101
 symbols, 101
screw replacement, 19, 20
self tests, 94
service
 contacting Agilent, 100
 ground instrument, 78
 ground modules, 20, 85

 web address, 95
shut down system, 84
software
 add-in, 77
 installation, 52, 56, 77
 updating, 77
 version requirements, 18, 44
space between instruments, 13
specifications, 76
standalone operation, 52
supplied accessories, 4
symbols
 safety, 101
system
 power, 95
 recovery, 100
 software, 77

T

target control port, 4
temperature, 75
thumb screws, measurement module, 20
thumb screws, module, 19
time correlation, 71
time correlation fixture, E5850A, 16, 71
tips for experienced users, 74
tools, optional, 77
touch off button, 12
Trigger In, 16, 71, 75
Trigger Out, 16, 71

U

update software, 77

V

version requirements, 18, 44
virus software, 14, 56

W

warnings, 101
web address
 probes, 18
 service/support, 95
windows
 power problems, 96

- updates, [56](#)
- welcome, [52](#)
- welcome questions, [54](#)
- Windows Firewall settings
 - changing, [87](#)
- workgroup, [52](#)
 - changing, [56](#)

